

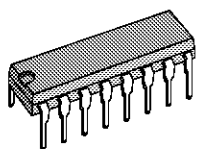
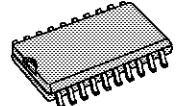
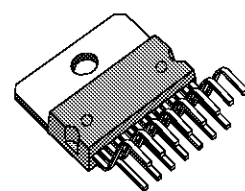
**STEPPER MOTOR DRIVER**

ADVANCE DATA

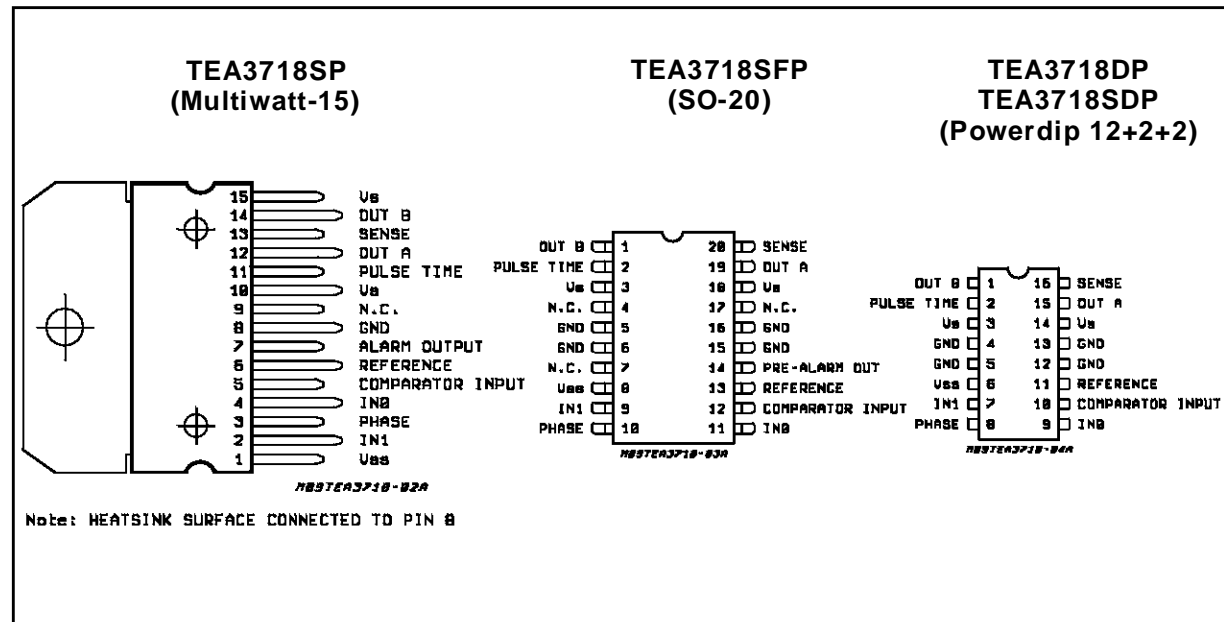
- HALF-STEP AND FULL-STEP MODE
- BIPOLAR DRIVE OF STEPPER MOTOR FOR MAXIMUM MOTOR PERFORMANCE
- BUILT-IN PROTECTION DIODES
- WIDE RANGE OF CURRENT CONTROL 5 TO 1500 mA
- WIDE VOLTAGE RANGE 10 TO 50 V
- DESIGNED FOR UNSTABILIZED MOTOR SUPPLY VOLTAGE
- CURRENT LEVELS CAN BE SELECTED IN STEPS OR VARIED CONTINUOUSLY
- THERMAL OVERLOAD PROTECTION
- ALARM OUTPUT OR PRE-ALARM OUTPUT (see internal table)

**DESCRIPTION**

The TEA3718 and TEA3718S are bipolar monolithic integrated circuits intended to control and drive the current in one winding of a bipolar stepper motor. The circuits consist of an LS-TTL compatible logic input, a current sensor, a monostable and an output stage with built-in protection diodes. Two TEA3718 or TEA3718S and a few external components form a complete control and drive unit for LS-TTL or microprocessor-controlled stepper motor systems.

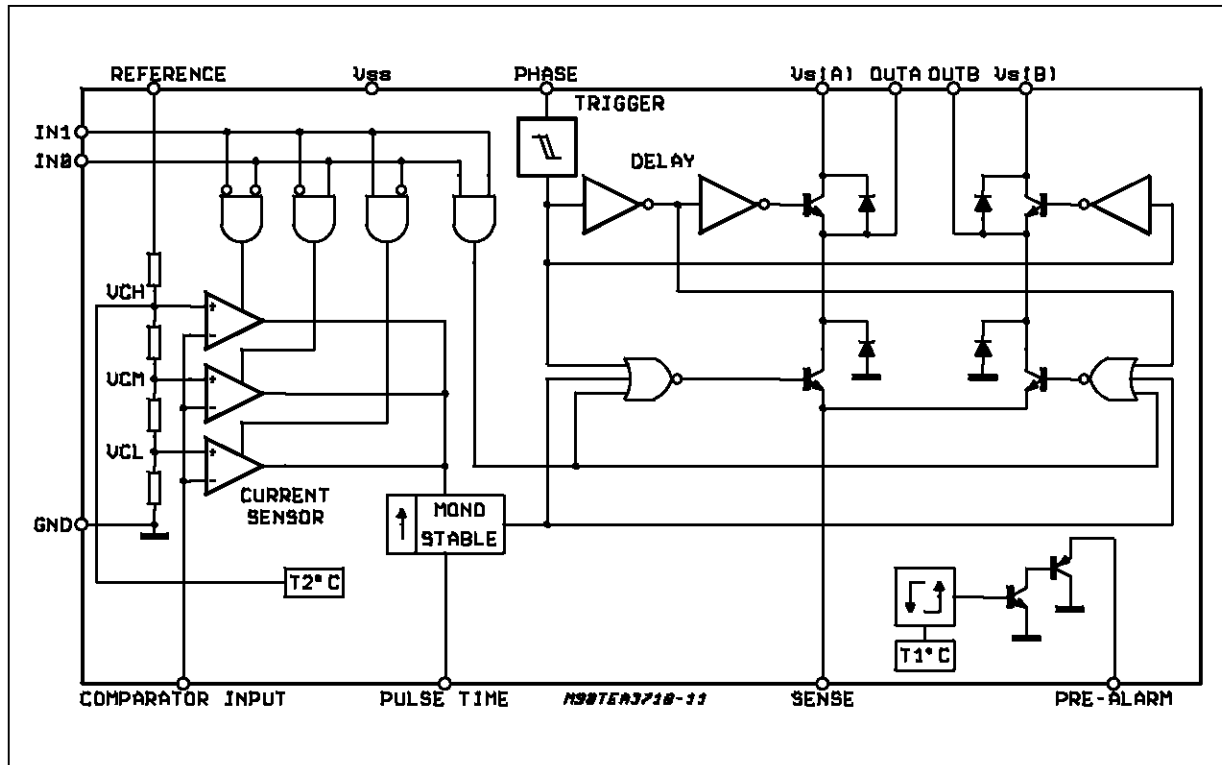
<p><b>Powerdip</b> 12 + 2 + 2</p>  <p><b>ORDERING NUMBERS :</b> TEA3718SDP TEA3718DP</p>	<p><b>SO-20</b></p>  <p><b>ORDERING NUMBER :</b> TEA3718SFP</p>
<p><b>MULTIWATT-15</b></p>  <p><b>ORDERING NUMBER :</b> TEA3718SP</p>	

**PIN CONNECTIONS (top views)**

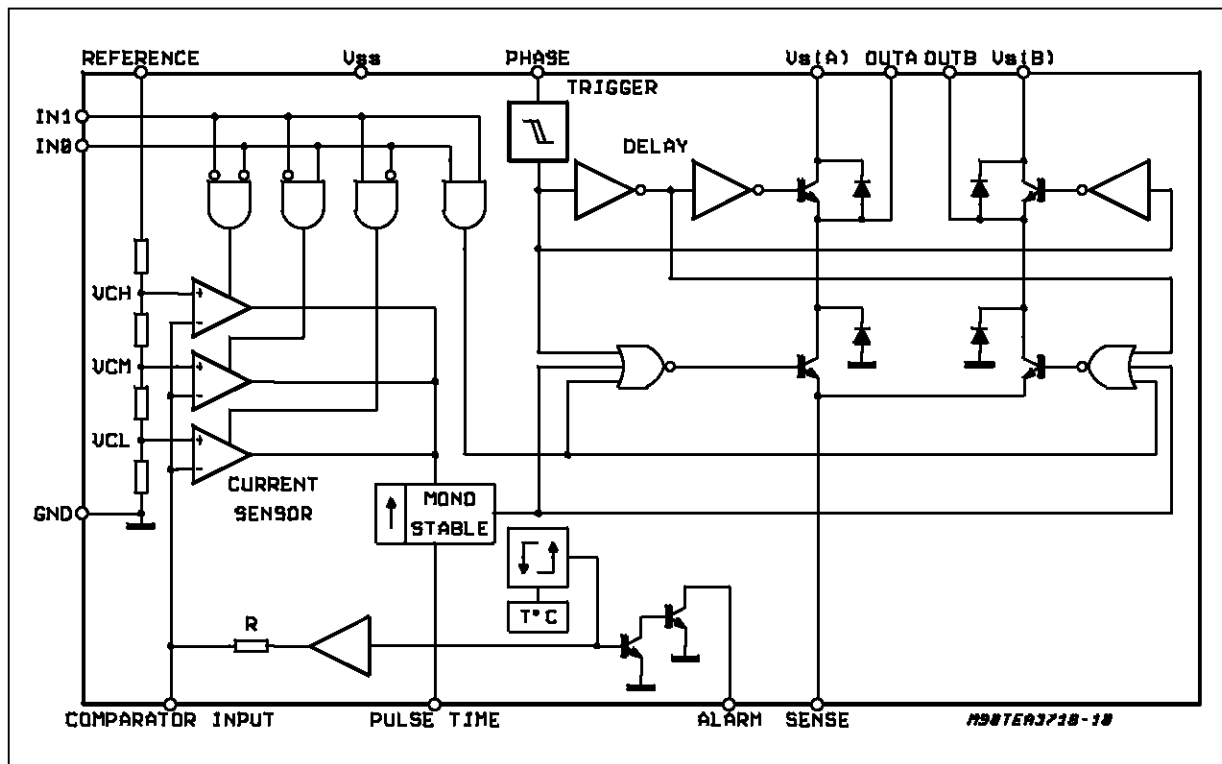


# TEA3718-TEA3718S

## BLOCK DIAGRAM TEA3718S



## BLOCK DIAGRAM TEA3718



## PIN FUNCTIONS

Name	Function
OUT B	Output Connection (with pin OUTA). The output stage is a "H" bridge formed by four transistors and four diodes suitable for switching applications.
PULSE TIME	A parallel RC network connected to this pin sets the OFF time of the lower power transistors. The pulse generator is a monostable triggered by the rising edge of the output of the comparators ( $t_{off} = 0.69 R_T C_T$ ).
V <sub>S(B)</sub>	Supply Voltage Input for Half Output Stage
GND	Ground Connection. In SO-20L and Powerdip these pins also conduct heat from die to printed circuit copper.
V <sub>SS</sub>	Supply Voltage Input for Logic Circuitry
IN1	This pin and pin IN0 are logic inputs which select the outputs of three comparators to set the current level. Current also depends on the sensing resistor and reference voltage. See truth table.
PHASE	This TTL-compatible logic input sets the direction of current flow through the load. A high level causes current to flow from OUT A (source) to OUT B (sink). A Schmitt trigger on this input provides good noise immunity and a delay circuit prevents output stage short circuits during switching.
IN0	See INPUT 1
COMPARATOR INPUT	Input connected to the three comparators. The voltage across the sense resistor is feedback to this input through the low pass filter R <sub>c</sub> C <sub>c</sub> . The lower power transistor are disabled when the sense voltage exceeds the reference voltage of the selected comparator. When this occurs the current decays for a time set by R <sub>T</sub> C <sub>T</sub> , $T_{off} = 0.69 R_T C_T$ .
REFERENCE	A voltage applied to this pin sets the reference voltage of the three comparators. Reference voltage with the value of R <sub>S</sub> and the two inputs IN0 and IN1 determines the output current.
V <sub>S(A)</sub>	Supply voltage input for half output stage
OUT A	See pin OUT B
SENSE RESISTOR	Connection to lower emitters of output stage for insertion of current sense resistor
ALARM	When T <sub>j</sub> reaches T1°C the alarm output becomes low (TEA3718SP)
PRE-ALARM	When T <sub>j</sub> reaches T2°C the prealarm output becomes low (T2<T1) (TEA3718SFP)

## TEA3718-TEA3718S

### ABSOLUTE MAXIMUM RATINGS

Symbol	Parameters	Value	Unit
V <sub>SS</sub>	Supply Voltage	7	V
V <sub>S</sub>	Supply Voltage	50	V
V <sub>I</sub>	Input Voltage: Logic Inputs Analog Inputs Reference Input	6 V <sub>SS</sub> 15	V V V
i <sub>i</sub>	Input Current Logic Inputs Analog Inputs	-10 -10	mA mA
I <sub>O</sub>	Output Current	±1.5	A
T <sub>J</sub>	Junction Temperature	+150	°C
T <sub>op</sub>	Operating Ambient Temperature Range	0 to 70	°C
T <sub>stg</sub>	Storage Temperature Range	-55 to +150	°C

### THERMAL DATA

Symbol	Parameter	SO-20L	Powerdip	Multiwatt	Unit
R <sub>th(j-c)</sub>	Maximum Junction-case Thermal Resistance	16	11	3	°C/W
R <sub>th(j-a)</sub>	Maximum Junction-ambient Thermal Resistance	60 *	45 *	40	°C/W

\* Soldered on a 35 µm thick 4 cm<sup>2</sup> PC board copper area.

### RECOMMENDED OPERATING CONDITIONS

Symbol	Parameter	Min.	Typ.	Max.	Unit
V <sub>SS</sub>	Supply Voltage	4.75	5	5.25	V
V <sub>S</sub>	Supply Voltage	10	–	45	V
i <sub>m</sub>	Output Current	0.020	–	1.2	A
T <sub>amb</sub>	Ambient Temperature	0	–	70	°C
t <sub>r</sub>	Rise Time Logic Inputs	–	–	2	µs
t <sub>f</sub>	Fall Time Logic Inputs	–	–	2	µs

### COMPARISON TABLE

Device	Current	Package	Alarm	Pre-Alarm
TEA3718SDP	1.5A	Powerdip 12+2+2		not connected
TEA3718SFP	1.5A	SO-20L		x
TEA3718SP	1.5A	Multiwatt-15	X	
TEA3718DP	1.5A	Powerdip 12+2+2	not connected	

MAXIMUM POWER DISSIPATION

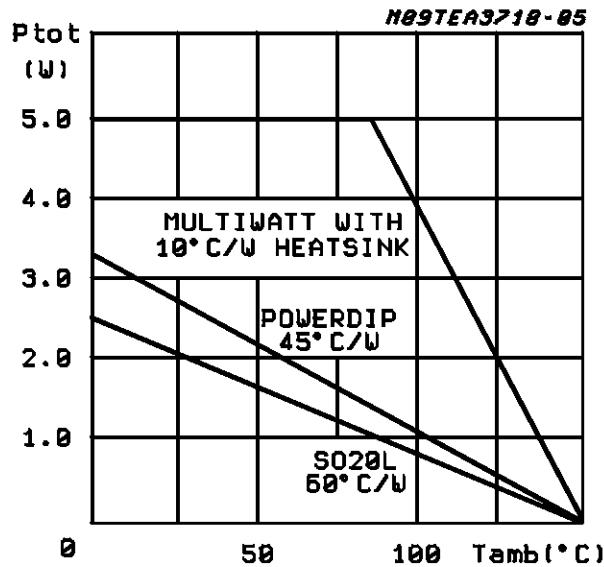
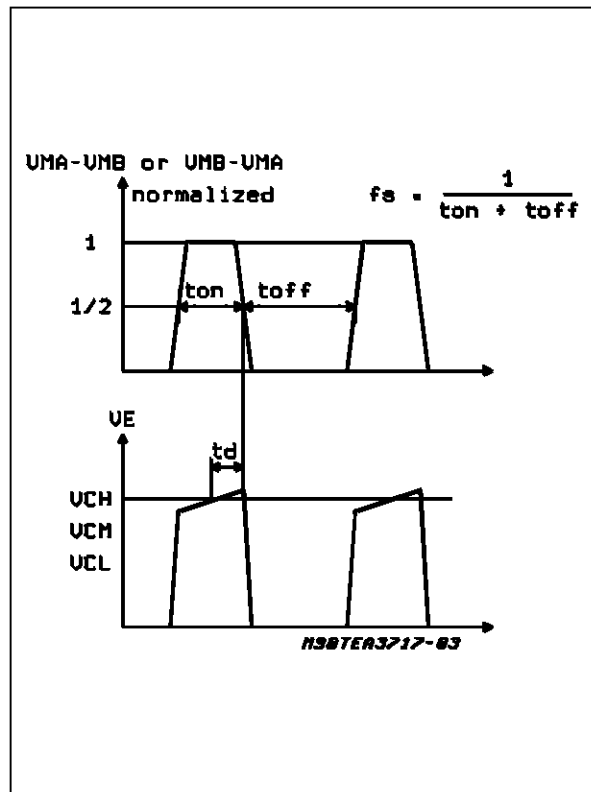
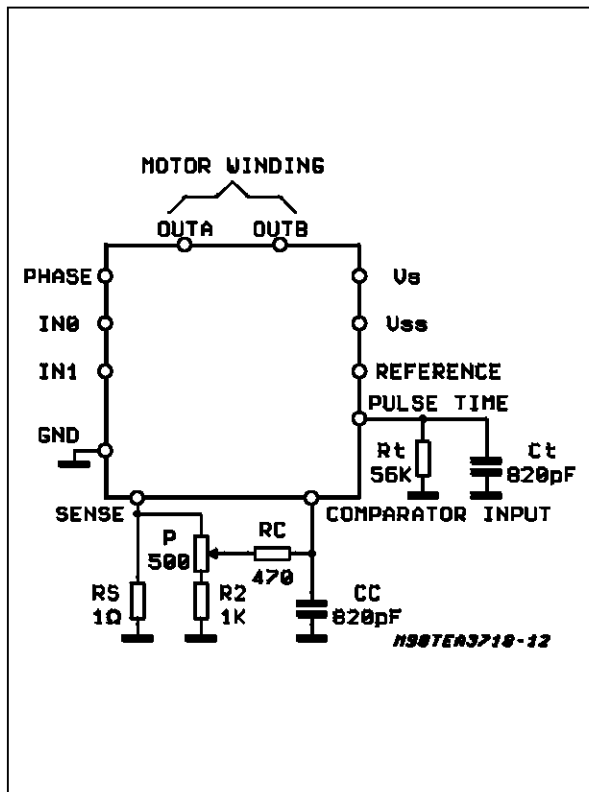


Figure 1.

Figure 2.



- $R_S = 1 \Omega$  INDUCTANCE FREE
- $R_C = 470 \Omega$
- $C_C = 820 \text{ pF}$  CERAMIC
- $R_1 = 56 \text{ k}\Omega$
- $C_1 = 820 \text{ pF}$  CERAMIC
- $P = 500 \Omega$
- $R_2 = 1 \text{ K}$

## TEA3718-TEA3718S

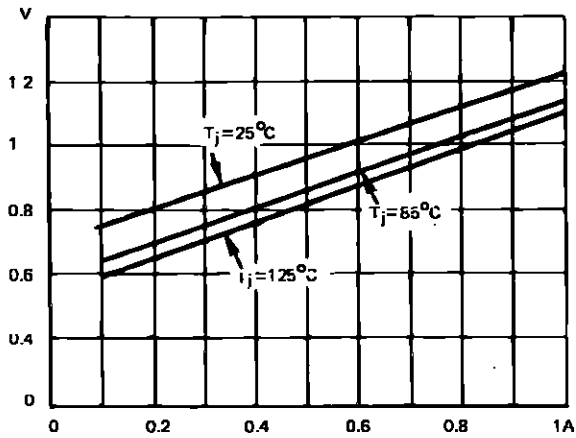
**ELECTRICAL CHARACTERISTICS** ( $V_{CC} = 5V, \pm 5\%$ ,  $V_{mm} = 10V$  to  $45V$ ,  $T_{amb} = 0$  to  $70^{\circ}C$   
( $T_{amb} = 25^{\circ}C$  for TEA3718FP/SFP) unless otherwise specified)

Symbol	Parameter	Min.	Typ.	Max.	Unit	
$I_{CC}$	Supply Current	-	-	25	mA	
$V_{IH}$	High Level Input Voltage - Logic Inputs	2	-	-	V	
$V_{IL}$	Low Level Input Voltage - Logic Inputs	-	-	0.8	V	
$I_{IH}$	High Level Input Current - Logic Inputs	-	-	20	$\mu A$	
$I_{IL}$	Low Level Input Current - Logic Inputs ( $V_I = 0.4V$ )	-0.4	-	-	mA	
$V_{CH}$	Comparator Thershold Voltage ( $V_R = 5V$ )	$I_O = 0$ $I_1 = 0$	390	420	440	mV
$V_{CM}$		$I_O = 0$ $I_1 = 0$	230	250	270	mV
$V_{CL}$		$I_O = 0$ $I_1 = 1$	65	80	90	mV
$I_{CO}$	Comparator Input Current	-20	-	20	$\mu A$	
$I_{off}$	Output Leakage Current ( $I_O = 0, I_1 = 1$ $T_{amb} = 25^{\circ}C$ )	-	-	100	$\mu A$	
$V_{sat}$	Total Saturation Voltage Drop ( $I_m = 1A$ )	SO20/Powerdip	-	-	2.8	V
		Multiwatt	-	-	3.2	V
$P_{tot}$	Total Power Disssipation - $I_m = 1A, f_s = 30KHz$	-	3.1	3.6	W	
$t_{off}$	Cut off Time (see figure 1 and 2, $V_{mm} = 10V, V_{ton} > 5\mu s$ )	25	30	35	ms	
$t_d$	Turn off Delay (see fig. 1 and 2, $T_{amb} = 25^{\circ}C, dV_C/dt > 50mV/\mu s$ )	-	1.6	-	$\mu s$	
$V_{sat}$	Alarm Output Saturation Voltage - $I_O = 2mA$ (Multiwatt)	-	0.8	-	V	
$I_{ref}$	Reference Input Current, $V_R = 5V$	-	0.4	1	mA	
$V_{sat}$	Source Diode Transistor Pair Saturation Voltage	Powerdip $I_m = 0.5A$	-	1.05	1.2 (1.3)	V
		Powerdip $I_m = 1A$	-	1.35	1.5 (1.7)	V
		Multiwatt $I_m = 0.5A$	-	-	1.3	V
		Multiwatt $I_m = 1A$	-	-	1.7	V
$V_f$	Diode Forward Voltage	$I_f = 0.5A$	-	1.1	1.5 (1.6)	V
		$I_f = 1A$	-	1.25	1.7 (1.9)	V
$I_{sub}$	Substrate Leakage Current	-	-	5	mA	
$V_{sat}$	Sink Diode Transistor Pair Saturation Voltage	Powerdip $I_m = 0.5A$	-	1	1.2 (1.3)	V
		Powerdip $I_m = 1A$	-	1.2	1.3 (1.5)	V
		Multiwatt $I_m = 0.5A$	-	-	1.3	V
		Multiwatt $I_m = 1A$	-	-	1.5	V
$V_f$	Diode Forward Voltage	$I_f = 0.5A$	-	1	1.4 (1.6)	V
		$I_f = 1A$	-	1.1	1.5 (1.9)	V

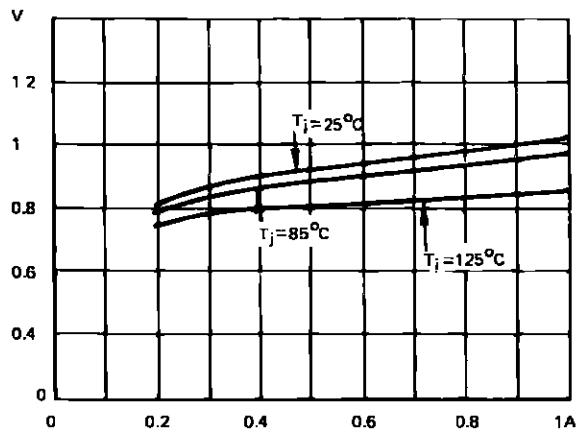
Notes:

(...) Only for TEA3718SFP mounted in SO-20L package.

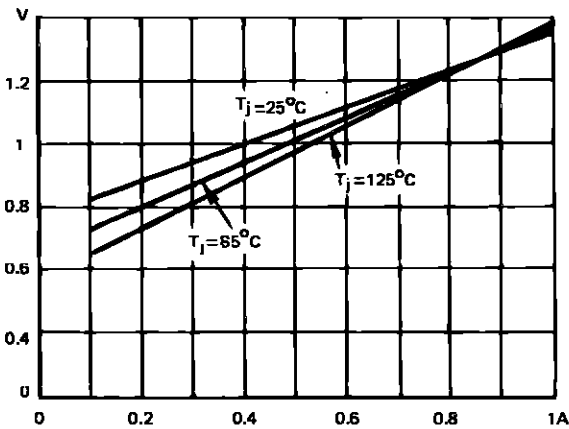
SINK DRIVER  $V_{CE sat}$  VS  $I_{OUT}$  and  $T_j$



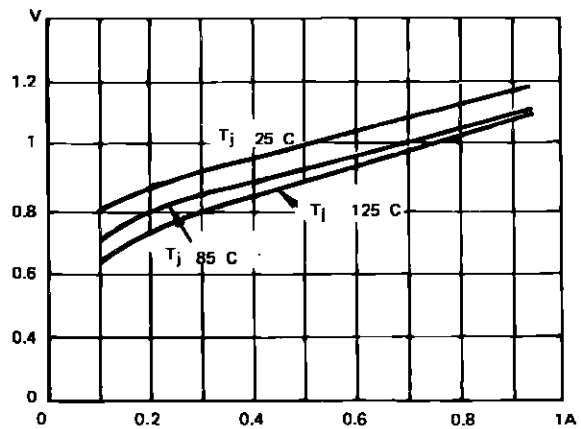
LOWER DIODE  $V_F$  VS  $I_{OUT}$  and  $T_j$



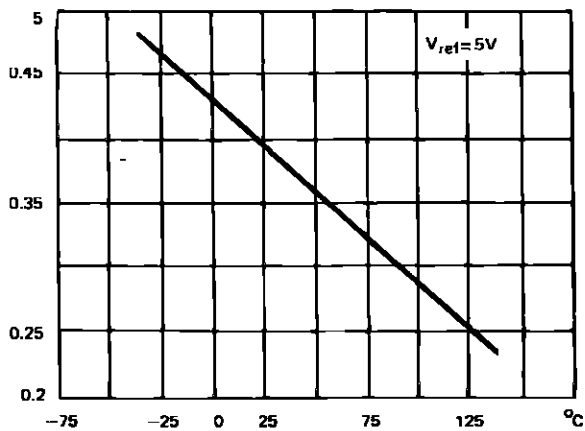
SOURCE DRIVER  $V_{CE sat}$  VS  $I_{OUT}$  and  $T_j$



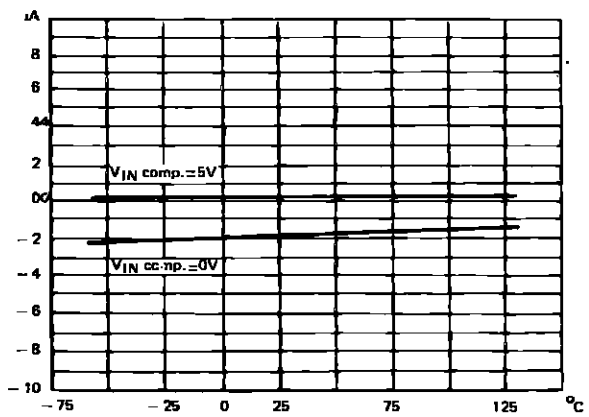
UPPER DIODE  $V_F$  VS  $I_{OUT}$  and  $T_j$



$I_{ref}$  VS JUNCTION TEMPERATURE



COMPARATOR INPUT CURRENT VS  $T_j$  and  $V_C$



# TEA3718-TEA3718S

## FUNCTIONAL BLOCKS

Figure A: ALARM OUTPUT (TEA3718SP - TEA3718DP)

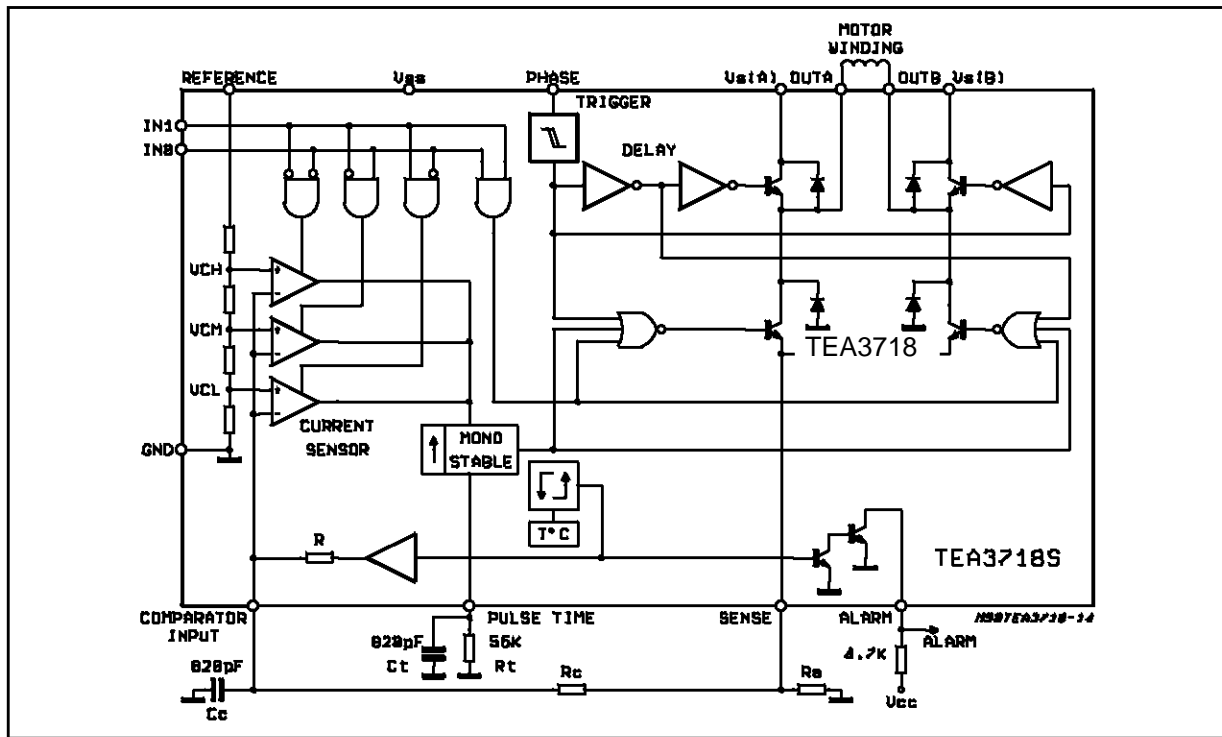
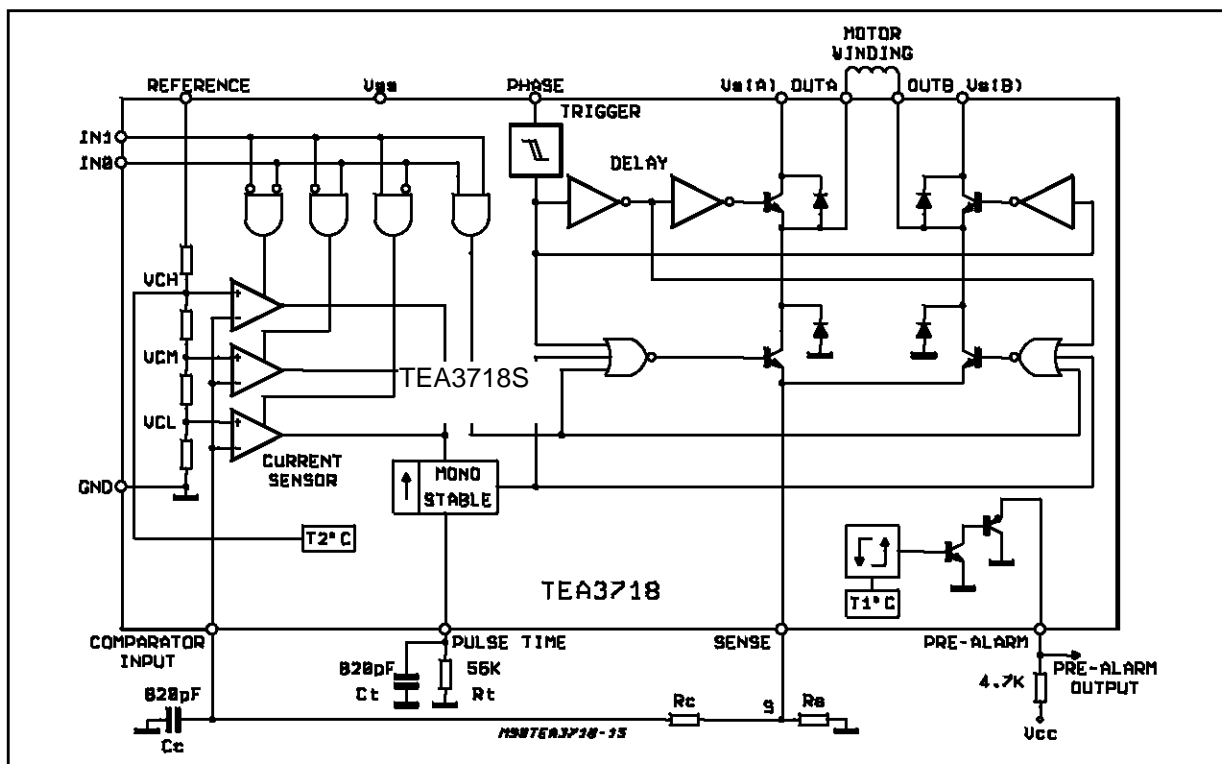


Figure B: PRE-ALARM OUTPUT (TEA3718SDP - TEA3718SFP)





**ALARM OUTPUTS** (TEA3718SP - TEA3718DP)  
 The alarm output becomes low when the junction temperature reaches T°C.

When an alarm condition occurs, parts of the supply voltage (dividing bridge R - R<sub>C</sub>) is fed to the comparator input pin (Fig. A)

Depending of the R<sub>C</sub>C value the behaviour of the circuit is different on alarm condition:

- 1) R<sub>C</sub> > 80Ω ⇒ the output stage is switched off
- 2) R<sub>C</sub> > 60Ω ⇒ the current in the motor windings is reduced according to the approximate formula: (see also fig. E and F)

$$I_m = \frac{V_{TH}}{R_s} - \frac{V_{CC}}{R + R_c} \cdot \frac{R_c}{R_s}$$

with V<sub>TH</sub> = Threshold of the comparator (V<sub>CH</sub>, V<sub>CM</sub>, V<sub>CL</sub>) R = 700Ω (typical)

For several Multiwatt packages a common detection can be obtained as in Fig. D

**PRE-ALARM OUTPUT**

When the junction temperature reaches T1°C (typ. = 170°C) a prealarm signal is generated.

Soft thermal protection occurs when function temperature reaches T2 (T2 > T1)

Figure C: Alarm Detection for Powerdip Package

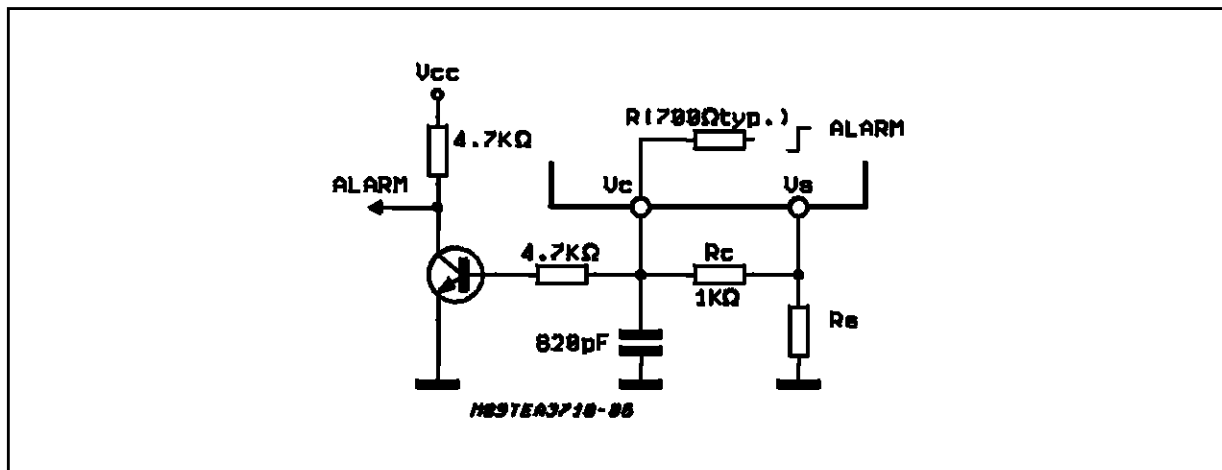
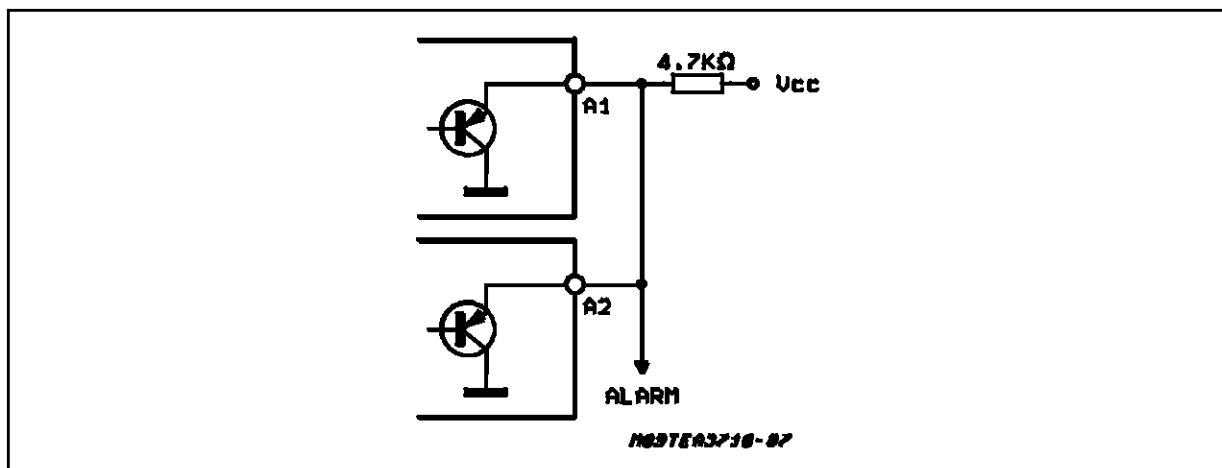
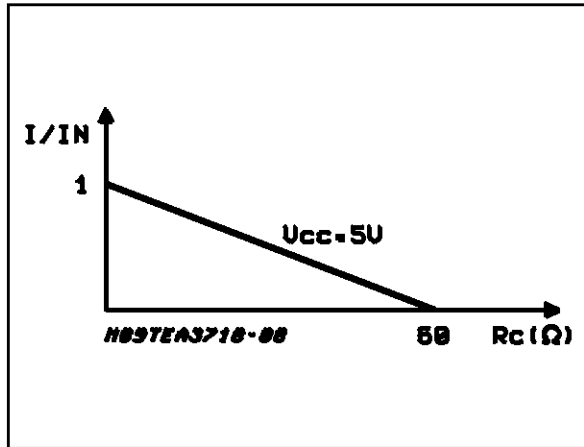


Figure D: CommonDetection for Several Multiwatt Package

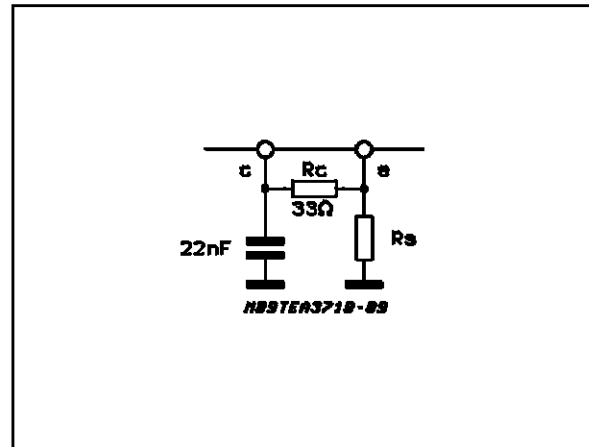


# TEA3718-TEA3718S

**Figure E:** (typical curve) Current Reduction in the Motor on Alarm Condition.

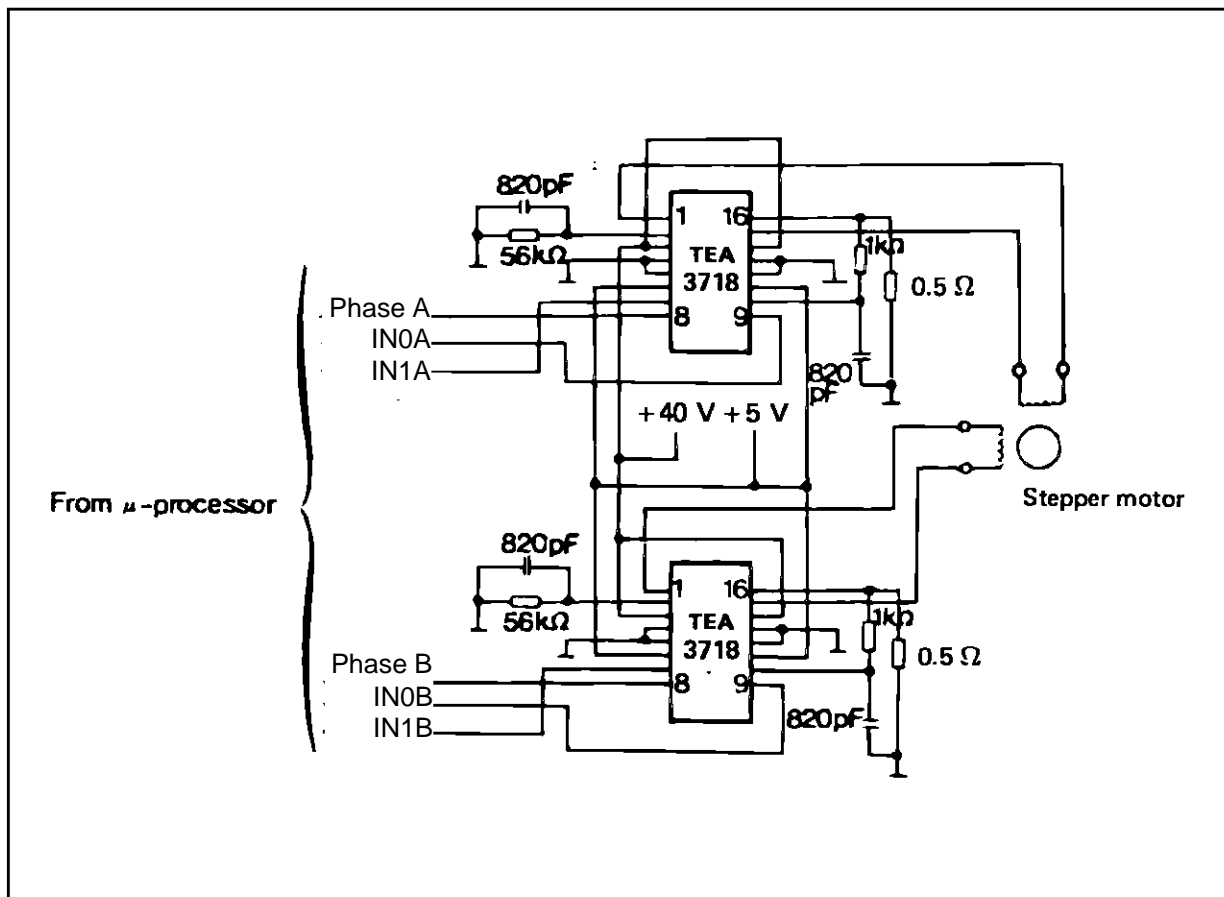


**Figure F:** ( $V_{ref}$  5V) Block Diagram for Half Current on Alarm Condition.



**Notes:** 1. Resistance values given here are for the  $V_{ch}$  threshold. They should be adjusted using other comparators threshold or other  $V_{ref}$  value.

## TYPICAL APPLICATION



## FUNCTIONAL DESCRIPTION

The circuit is intended to drive a bipolar constant current through one motor winding. The constant current is generated through switch mode regulation.

There is a choice of three different current levels with the two logic inputs IN0 and IN1. The current can also be switched off completely.

### INPUT LOGIC

If any of the logic inputs is left open, the circuit will treat it as a high level input.

IN0	IN1	Current Level
H	H	No Current
L	H	Low Current
H	L	Medium Current
L	L	Maximum Current

**PHASE** - This input determines the direction of current flow in the winding, depending on the motor connections. The signal is fed through a Schmidt-trigger for noise immunity, and through a time delay in order to guarantee that no short-circuit occurs in the output stage during phase-shift. High level on the PHASE input causes the motor current flow from Out A through the winding to Out B.

**I<sub>H0</sub>** and **I<sub>H1</sub>** - The current level in the motor winding is selected with these inputs. The values of the different current levels are determined by the reference voltage  $V_R$  together with the value of the sensing resistor  $R_S$ .

### CURRENT SENSOR

This part contains a current sensing resistor ( $R_S$ ), a low pass filter ( $R_C$ ,  $C_C$ ) and three comparators. Only one comparator is active at a time. It is activated by the input logic according to the current level chosen with signals IN0 and IN1. The motor current flows through the sensing resistor  $R_S$ . When the current has increased so that the voltage across  $R_S$  becomes higher than the reference voltage on the other comparator input, the comparator output goes high, which triggers the pulse generator and its output goes high during a fixed pulse time ( $t_{off}$ ), thus switching off the power feed to the motor winding, and causing the motor current to decrease during  $t_{off}$ .

### SINGLE-PULSE GENERATOR

The pulse generator is a monostable triggered on the positive going edge of the comparator output. The monostable output is high during the pulse time,  $t_{off}$ , which is determined by the timing components  $R_t$  and  $C_t$ .

$$t_{off} = 0.69 \cdot R_t \cdot C_t$$

The single pulse switches off the power feed to the motor winding, causing the winding current to decrease during  $t_{off}$ .

If a new trigger signal should occur during  $t_{off}$ , it is ignored.

### OUTPUT STAGE

The output stage contains four Darlington transistors and four diodes, connected in an H-bridge. The two sinking transistors are used to switch the power supplied to the motor winding, thus driving a constant current through the winding.

It should be noted however, that it is not permitted to short circuit the outputs.

$V_{SS}$ ,  $V_S$ ,  $V_R$

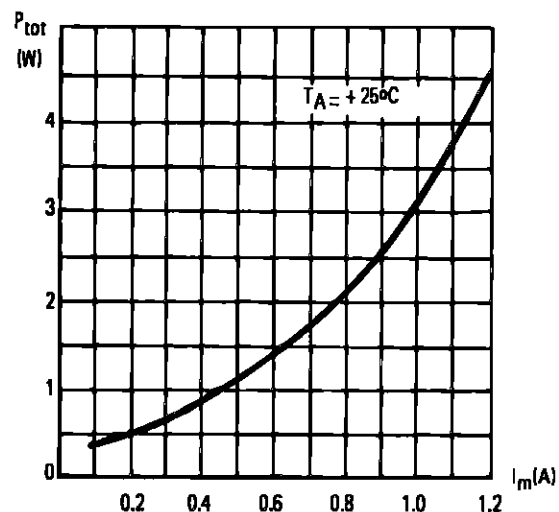
The circuit will stand any order of turn-on or turn-off the supply voltages  $V_{SS}$  and  $V_S$ . Normal  $dV/dt$  values are then assumed.

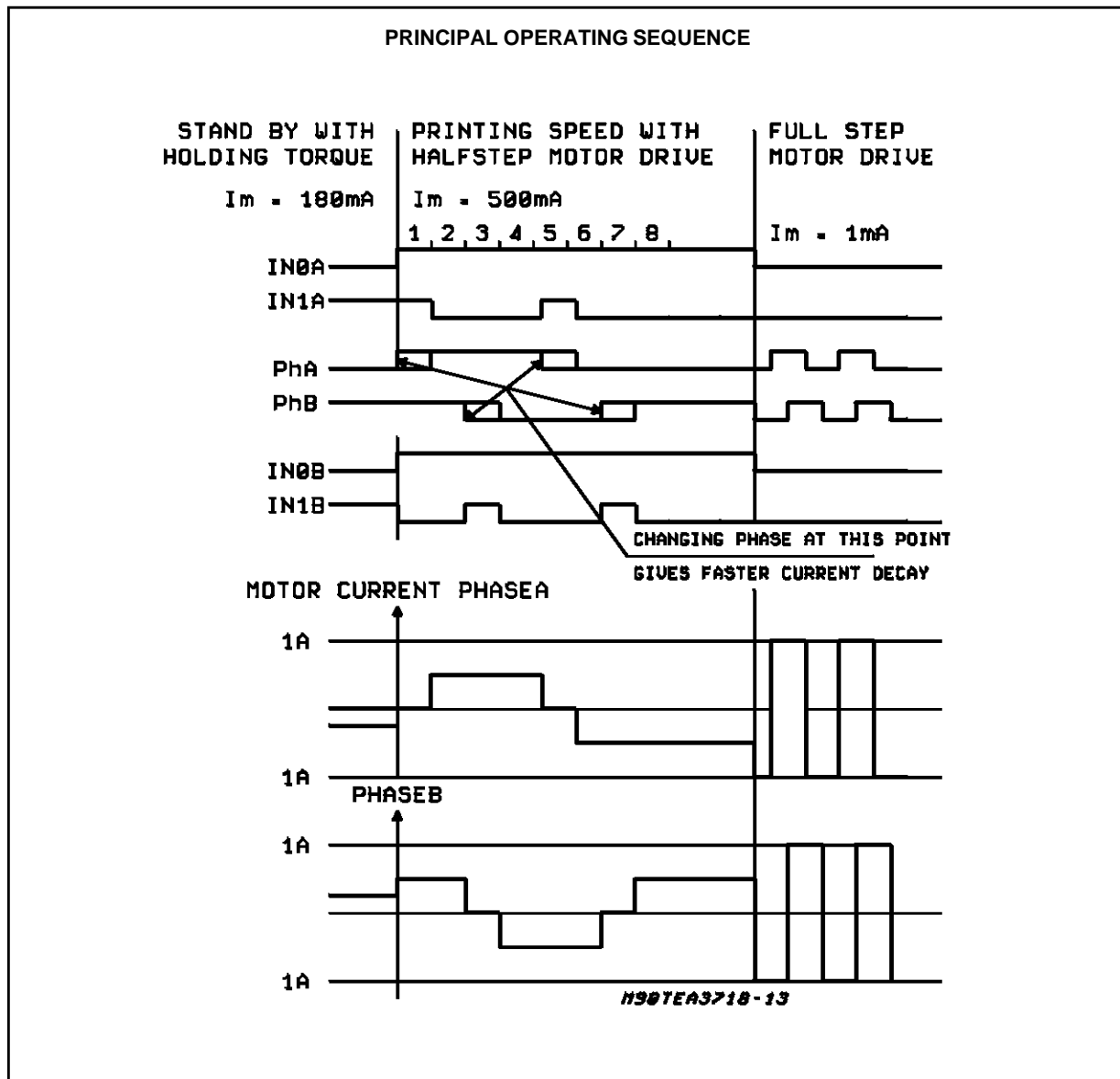
Preferably,  $V_R$  should be tracking  $V_{SS}$  during power-on and power-off if  $V_S$  is established.

### ANALOG CONTROL

The current levels can be varied continuously if  $V_R$  is varied with a circuit varying the voltage on the comparator terminal.

### POWER LOSSES $V_S$ OUTPUT CURRENT





**APPLICATION NOTES**

**MOTOR SELECTION**

Some stepper motors are not designed for continuous operation at maximum current. As the circuit drives a constant current through the motor, its temperature might increase exceedingly both at low and high speed operation.

Also, some stepper motors have such high core losses that they are not suited for switch mode current regulation.

**UNUSED INPUTS**

Unused inputs should be connected to proper voltage levels in order to get the highest noise immunity.

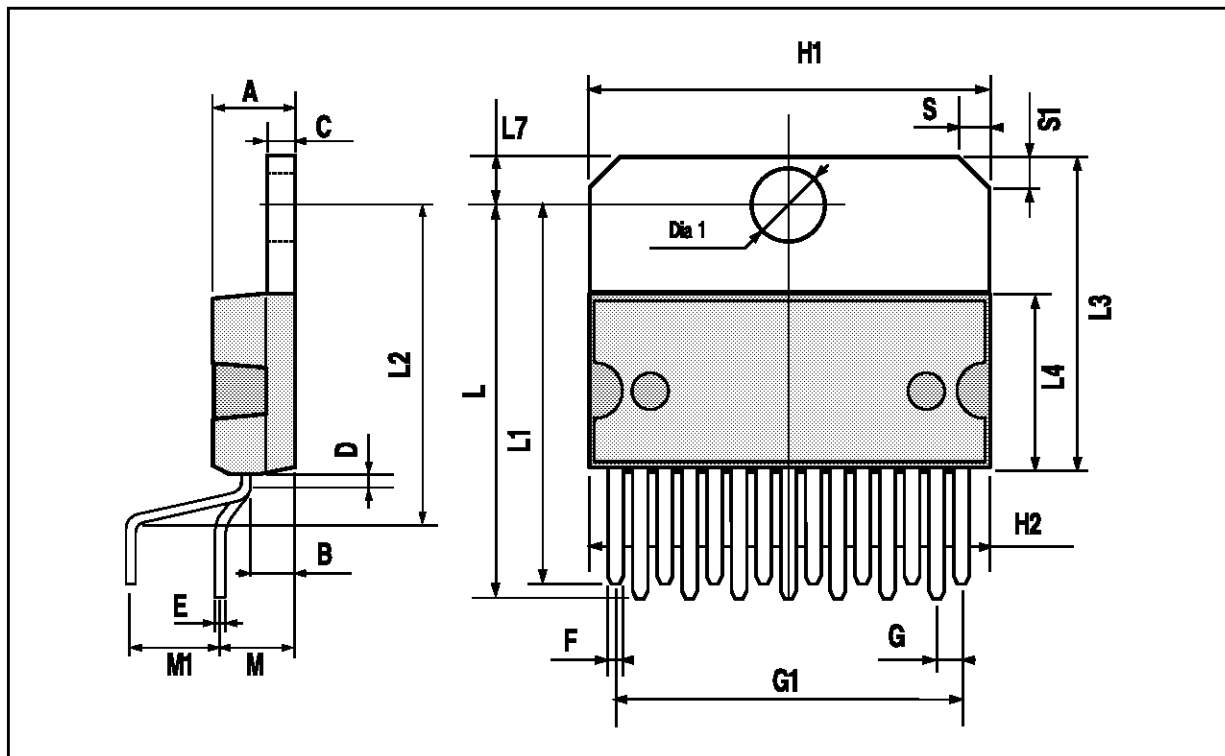
**INTERFERENCE**

As the circuit operates with switch mode current regulation, interference generation problems might arise in some applications. A good measure might then be to decouple the circuit with a 15 nF ceramic capacitor, located near the package between power line Vs and ground.

The ground lead between Rs, Cc and circuit GND should be kept as short as possible. This applies also to the lead between the sensing resistor Rs and point S, see FUNCTIONAL BLOCKS.

## MULTIWATT15 PACKAGE MECHANICAL DATA

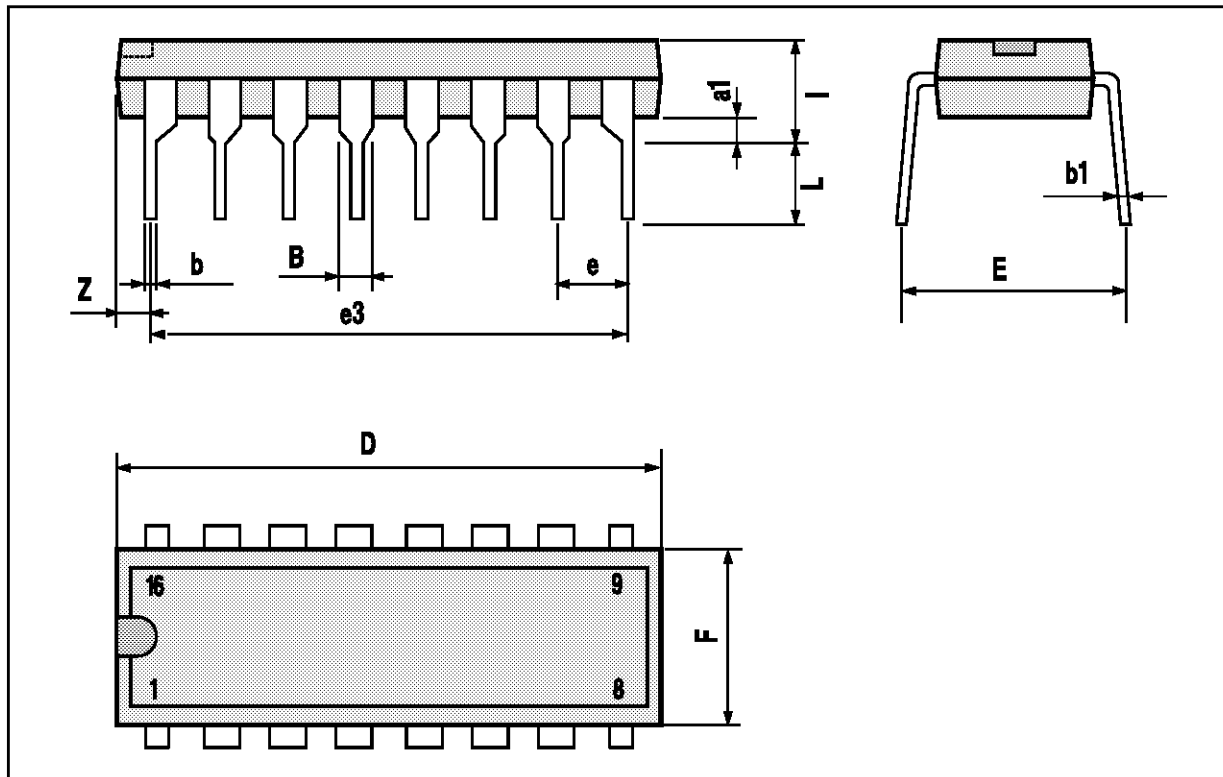
DIM.	mm			inch		
	MIN.	TYP.	MAX.	MIN.	TYP.	MAX.
A			5			0.197
B			2.65			0.104
C			1.6			0.063
D		1			0.039	
E	0.49		0.55	0.019		0.022
F	0.66		0.75	0.026		0.030
G	1.02	1.27	1.52	0.040	0.050	0.060
G1	17.53	17.78	18.03	0.690	0.700	0.710
H1	19.6			0.772		
H2			20.2			0.795
L	21.9	22.2	22.5	0.862	0.874	0.886
L1	21.7	22.1	22.5	0.854	0.870	0.886
L2	17.65		18.1	0.695		0.713
L3	17.25	17.5	17.75	0.679	0.689	0.699
L4	10.3	10.7	10.9	0.406	0.421	0.429
L7	2.65		2.9	0.104		0.114
M	4.25	4.55	4.85	0.167	0.179	0.191
M1	4.63	5.08	5.53	0.182	0.200	0.218
S	1.9		2.6	0.075		0.102
S1	1.9		2.6	0.075		0.102
Dia1	3.65		3.85	0.144		0.152



**TEA3718-TEA3718S**

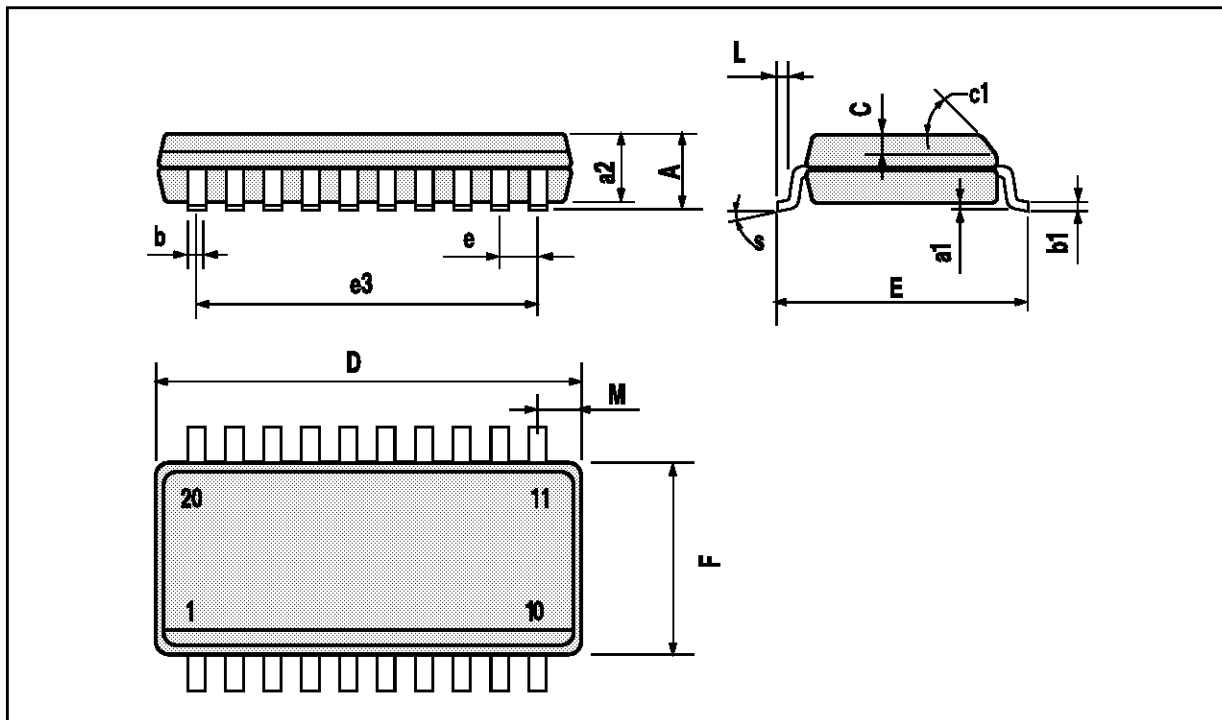
**POWERDIP 16 PACKAGE MECHANICAL DATA**

DIM.	mm			inch		
	MIN.	TYP.	MAX.	MIN.	TYP.	MAX.
a1	0.51			0.020		
B	0.85		1.40	0.033		0.055
b		0.50			0.020	
b1	0.38		0.50	0.015		0.020
D			20.0			0.787
E		8.80			0.346	
e		2.54			0.100	
e3		17.78			0.700	
F			7.10			0.280
I			5.10			0.201
L		3.30			0.130	
Z			1.27			0.050



## SO20 PACKAGE MECHANICAL DATA

DIM.	mm			inch		
	MIN.	TYP.	MAX.	MIN.	TYP.	MAX.
A			2.65			0.104
a1	0.1		0.3	0.004		0.012
a2			2.45			0.096
b	0.35		0.49	0.014		0.019
b1	0.23		0.32	0.009		0.013
C		0.5			0.020	
c1	45 (typ.)					
D	12.6		13.0	0.496		0.512
E	10		10.65	0.394		0.419
e		1.27			0.050	
e3		11.43			0.450	
F	7.4		7.6	0.291		0.299
L	0.5		1.27	0.020		0.050
M			0.75			0.030
S	8 (max.)					



Information furnished is believed to be accurate and reliable. However, SGS-THOMSON Microelectronics assumes no responsibility for the consequences of use of such information nor for any infringement of patents or other rights of third parties which may result from its use. No license is granted by implication or otherwise under any patent or patent rights of SGS-THOMSON Microelectronics. Specifications mentioned in this publication are subject to change without notice. This publication supersedes and replaces all information previously supplied. SGS-THOMSON Microelectronics products are not authorized for use as critical components in life support devices or systems without express written approval of SGS-THOMSON Microelectronics.

© 1994 SGS-THOMSON Microelectronics - All Rights Reserved  
MULTIWATT® is a Registered Trademark of the SGS-THOMSON Microelectronics

SGS-THOMSON Microelectronics GROUP OF COMPANIES  
Australia - Brazil - France - Germany - Hong Kong - Italy - Japan - Korea - Malaysia - Malta - Morocco - The Netherlands - Singapore -  
Spain - Sweden - Switzerland - Taiwan - Thailand - United Kingdom - U.S.A.