

LCD Module Technical Specification

Type No. **T-51963GD035J-MLW-AFN**



Approved by (Quality Assurance Division)

S.Sano

Checked by (ACI Engineering Division)

T.Noguchi

Prepared by (ACI Engineering Division)

Table of Contents

1. General Specifications	2
2. Operating Conditions	2
3. Electrical Specifications	3
4. Optical Specifications	11
5. I/O Terminal	17
6. Test	21
7. Appearance Standards	22
8. Code System of Production Lot	24
9. Type Number	24
10. Applying Precautions	24
11. Precautions Relating Product Handling	25
12. Warranty	26

Revision History

Rev.	Date	Page	Comment

1. General Specifications

Screen Size	:	3.52 inches (8.9cm)
Display Mode	:	Normally White
Driving Method	:	a-Si TFT active matrix format
Display Format	:	240 × 3 [R.G.B] (W) × 320 (H)
Resolution	:	720(W) x 320(H)
Dot Pitch	:	0.0745(W) x 0.2235(H) mm
Pixel Configuration	:	RGB Stripe
Active Area	:	53.64(W) x 71.52(H) mm
Outline Dimension	:	65.0(W) x 86.2(H) x 3.4.0(D) mm
Weight	:	46g max.
Backlight	:	LED Backlight / White
Attached Drawing	:	Dimensional Outline T-51963AB base

2. Operating Conditions

Item		Conditions	Temperature Range	Remark
Operating Temperature Range	LCD Module w/Backlight	Panel Surface	-20 ~ 70°C	Note2-1,2-2
Storage Temperature Range	LCD Module w/Backlight	Panel Surface	-30 ~ 70°C	Note2-3

Note2-1: Operating temperature range defines the operation only and the contrast, response time and other display optical characteristics are set at Ta=+25°C.

Note2-2: Panel surface temperature indicates the temperature of the backlight panel surface on the five points from the four corners and the center. Also note that the panel temperature of backlight side is 10°C (reference value) higher than the other side.

Note2-3: Backlight is not activated.

3. Electrical Specifications

3.1. Absolute Maximum Ratings

Item	Symbol	Conditions	Min.	Max.	Units
Supply voltage	V _{DDA}	Ta=25±5°C V _{SS} =0V	0	+6.0	V
	V _{GH}		0	+18.0	V
	V _{GL}		-15.0	0	V
Data Signal Voltage	V _{DDD}		-0.3	+6.0	V

Note: Absolute maximum ratings should not exceed the limit any time. If the product exceeds the limit, it may cause damage. Please be cautious to the changes in supply voltage, connection parts, surge of signals, and ambient temperature.

3.2. Description

Item	Description	Remark
Display Size	3.5" (8.9cm)	
Display Method	TN full color (transflective type)	Normally White
Driving Method	a-Si TFT Active Matrix Line Scanning	
Pixel Alignment	RGB Stripe alignment	
Visual Signal Input Method	RGB × 6bits CMOS Level	
Controlled Signal Input Method	CMOS Level	
Backlight	LED, Edge light	

3.3. Pixel Alignment

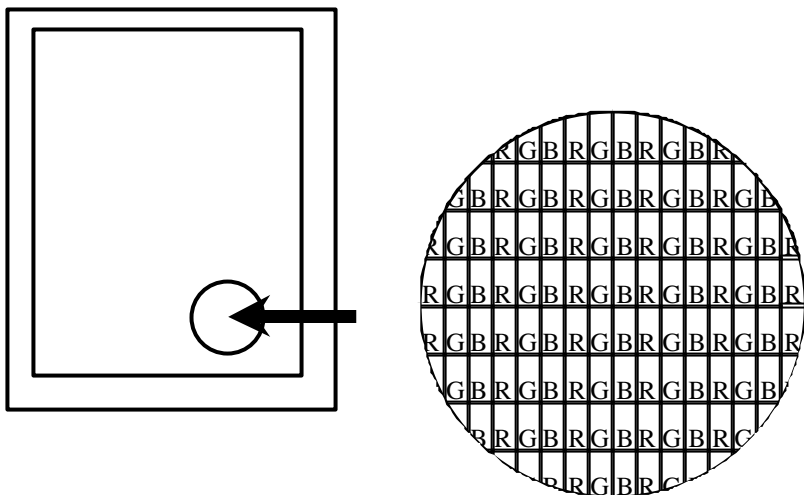

3.4. Operation Condition for LCD Module

Ta=25°C

Item	Symbol	Min.	Typ.	Max.	Units	Remark
Signal	V _{IL}	-	0	0.8	V	
	V _{IH}	2.7	3.3	3.6	V	V _{DDD} =MAX
Supply Voltage	V _{DDD}	3.0	3.3	3.6	V	
	V _{DDA}	4.9	5.0	5.1	V	
Gate Driver Plus	V _{GH}	15.5	16.0	16.5	V	
Gate Driver Minus	V _{GL}	-12.5	-12.0	-11.5	V	
Digital	I _{DDD}	-	1.6	-	mA	
Analog	I _{DDA}	-	8.0	-	mA	
Gate Driver	I _{GH}	-	0.05	0.10	mA	
Gate Driver	I _{GL}	-	0.05	0.10	mA	
Common Electrode Voltage	V _{COMAC}	-	± 2.5	-	V _{P-P}	
	V _{COMDC}	0.6	1.6	2.6	V	

Note: The recommended conditions are the range of operation guaranteed and operating beyond the range, the operation will not be guaranteed even if it is within the absolute values.

Gamma:Target 2.2

3.5. Timing Specification

3.5.1. Input signal waveform

V_{DD}=3.3V, T_a=25°C

Item	Symbol	Min.	Typ.	Max.	Units
CLK Period	T _{OSC}	199	183	146	ns
Data Setup Time	T _{SU}	12	-	-	ns
Data Hold Time	T _{HD}	12	-	-	ns
HD Period	T _H	260	280	300	T _{OSC}
HD Pulse Width	T _{HS}	2	10	-	T _{OSC}
Horizontal Active Time	T _{HA}	-	240	-	T _{OSC}
VD Period	T _{VX}	323	326	340	T _H
VD Pulse Width	T _{VS}	1	3	5	T _H
Vertical Active Time	T _{VA}	-	320	-	T _{OSC}
VD-DENA Time	T _{VSE}	-	4	-	T _H
HD-DENA Time	T _{HE}	10	30	63	T _{OSC}
DENA Pulse Width	T _{EP}	-	240	-	T _{OSC}
HD-POL Time	T _{HP}	-	7	-	T _{OSC}

a. Pixel Timing Chart

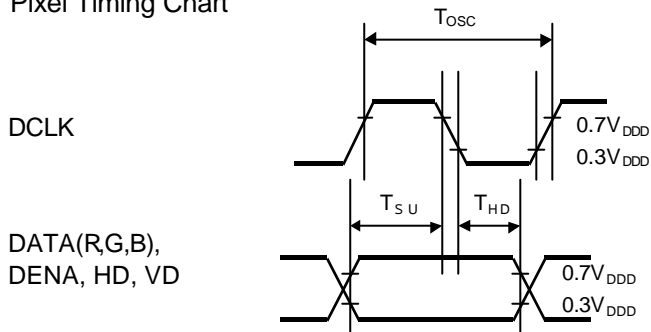

b. Horizontal Timing Chart

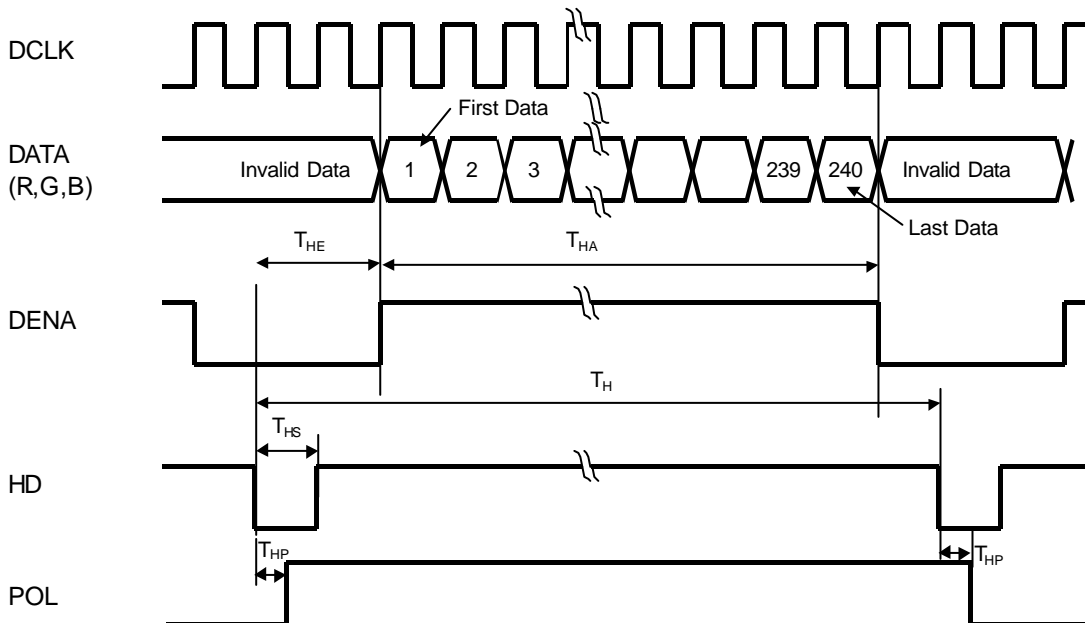

c. Vertical Timing Chart

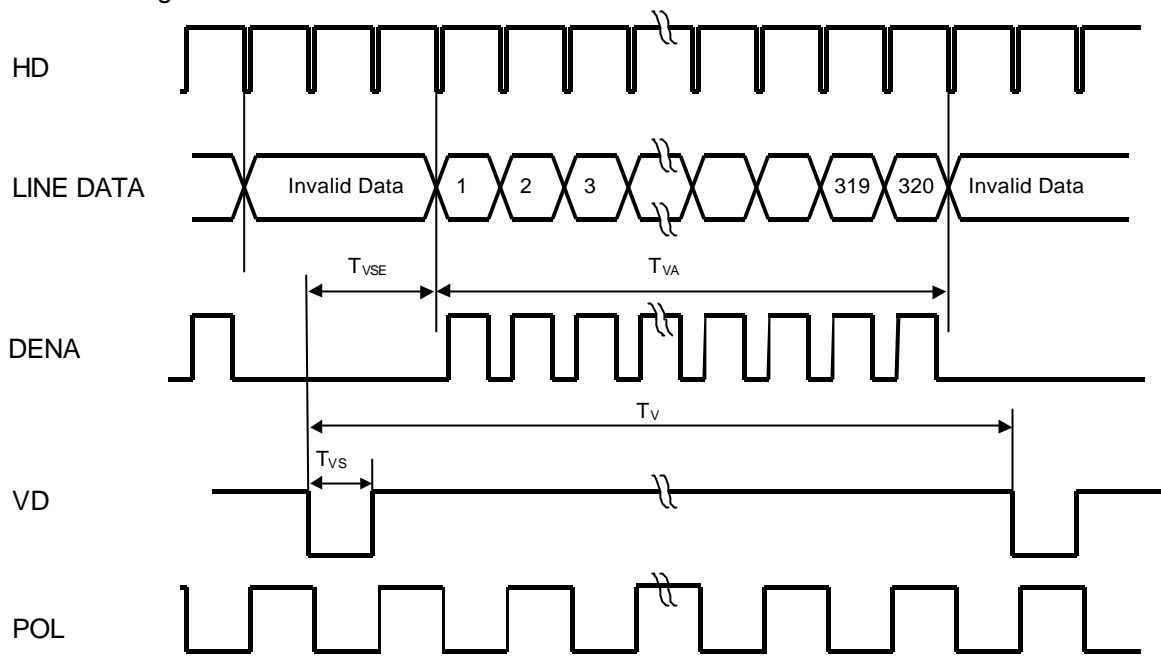

3.6. Power Supply Sequence

Please follow below for power supply sequence.

When the power is on, all power source is assumed to be at 90% and when power is off, all power source is assumed to be at 10%.

Please avoid any single power source to be outside of the sequence written below.

Power ON Sequence	$V_{DDDD} \rightarrow V_{GH}/V_{GL} \rightarrow V_{DDA} \rightarrow \text{Data}$
Power OFF Sequence	$\text{Data} \rightarrow V_{DDA} \rightarrow V_{GH}/V_{GL} \rightarrow V_{DDDD}$

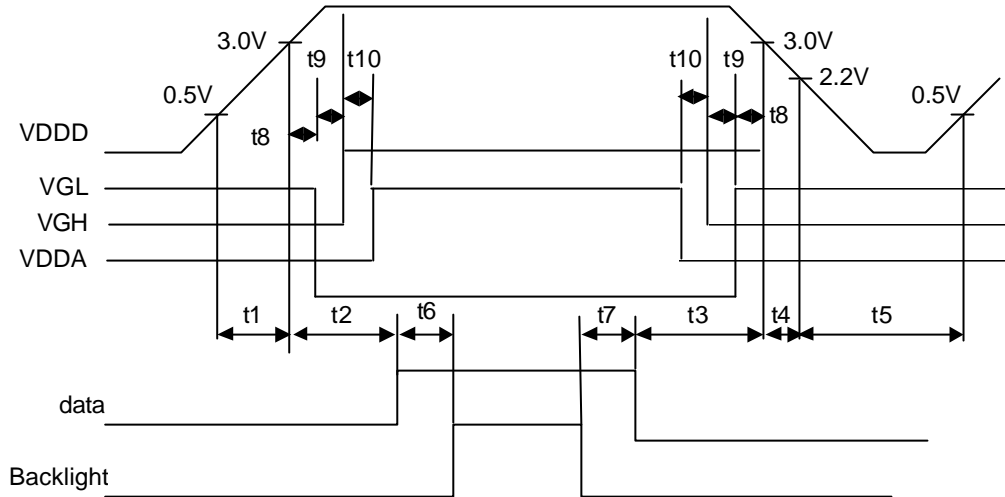

Symbol	Min.	Typ.	Max.	Units
t1	0	-	10	ms
t2	0	-	50	ms
t3	20	-	1000	ms
t4	0	-	50	ms
t5	1000	-	-	ms
t6	200	-	-	ms
t7	0	-	-	ms
t8	0	-	10	ms
t9	0	-	10	ms
t10	0	-	10	ms

3.7.Reset Signal Timing

T-51963 is internally initialized by the global reset signal, RESET. The reset input must be held for at least 1ms after power is stable.

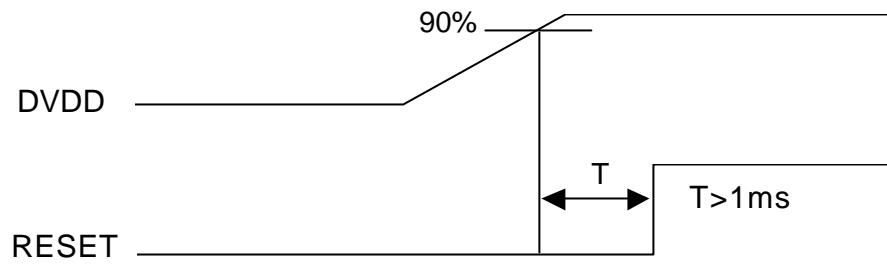

3.8.Scan Direction

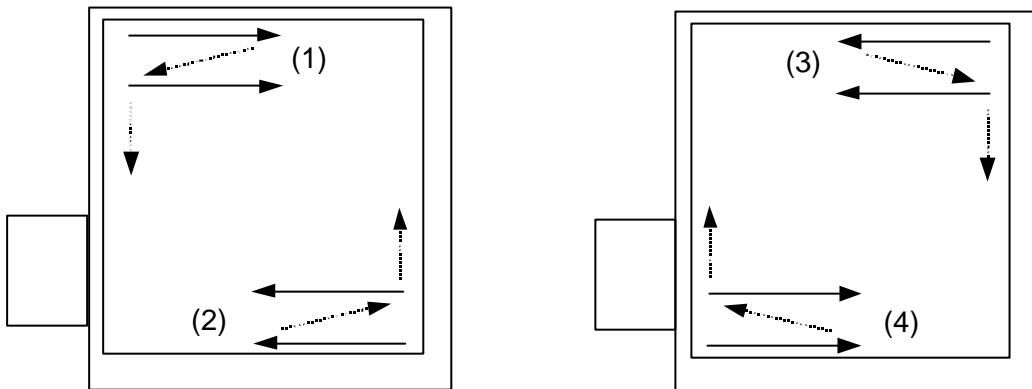

H=VDDD, L=GND

	L / R	U / L
(1)	H	L
(2)	L	H
(3)	L	L
(4)	H	H

3.9.VCOM Input Signal

T-51963 needs DC level shift circuit at customerside.

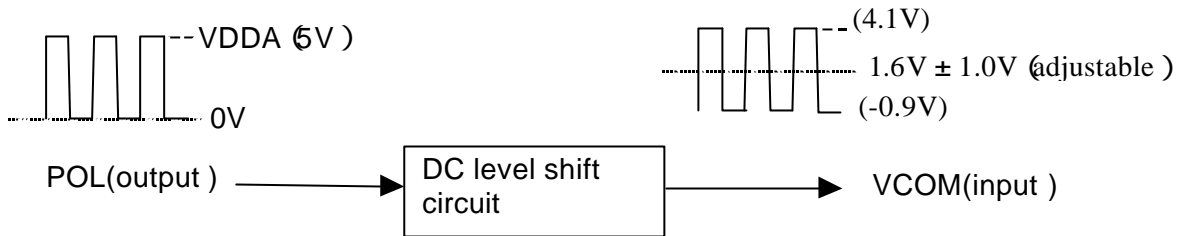

3.10. Backlight

3.10.1. Backlight Driving Section

Ta=25°C

Parameter	Symbol	Min.	Typ.	Max.	Units	Remark
LED Voltage	VL	-	21.6	25.2	V	
LED Current	IL	-	15	20	mA	
Power Consumption	WL	-	0.324	-	W	*
Backlight Life Time	BL	5000	-	-	Hrs	IL=15mA

* Calculated reference value(IL × VL)

4. Optical Specifications

	Item	Symbol	Conditions	Standard Value			Units	Method of Measurement	Remark	
			CR	Min.	Typ.	Max.				
Transmissive Mode	(1) Brightness	B	/	-	160	-	Cd/m ²	(D4-1a)	N4-1	
	(2) Contrast Ratio	CR	/	40	70	-	-		-	
	(3) White Chromacity	X	/	-	0.32	-	-			
		Y	/	-	0.35	-	-			
	(4) Brightness Uniformity	-	/	0.7	-	-	-	(D4-2)	N4-1	
	(5) Vertical Viewing Angle	Up	θ_U	≥ 10	-	40	-	Degree	(D4-3)	-
		Down	θ_D	≥ 10	-	40	-	Degree		
	(6) Horizontal Viewing Angle	Left	ϕ_L	≥ 10	-	40	-	Degree		
		Right	ϕ_R	≥ 10	-	40	-	Degree		
	(7) Response Time	Rise	τ	/	-	30	60	ms	(D4-4)	-
Decay		τ_d	/	-	50	100	ms			

Reflective Mode	(1) Contrast Ratio	CR	/	-	8	-	-	(D4-1b)	-
	(2) White Chromacity	X	/	-	0.32	-	-		-
		Y	/	-	0.33	-	-		
	(3) Reflectance	-	/	-	20	-	%	-	

(N4-1) : Under the condition of IL=15mA

◆ Conditions for Measuring

Environment: Dark room with no light or close to no light.

Temperature: $25 \pm 5^\circ\text{C}$

Humidity: 40~70%RH

◆ Optimal viewing angle (The angle with best contrast)

6 O'clock

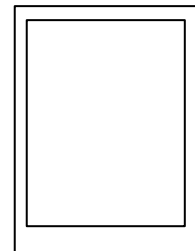

(D4-1a)

◆ Method of Brightness Measurement

1) Measuring Device

TOPCON BM-7, Measuring Field: 1°

2) Measuring Point

Center of Display $\theta=0^\circ$, $\phi=0^\circ$

On Conditions θ : A vertical angle from measuring direction to perpendicular.

ϕ : A horizontal angle from measuring direction to perpendicular.

3) Method of Measuring

Apply signal voltage (displayed in white) to maximize Brightness and measure brightness B (cd/m^2).

The distance between BM-7's front lens to surface panel is 500mm.

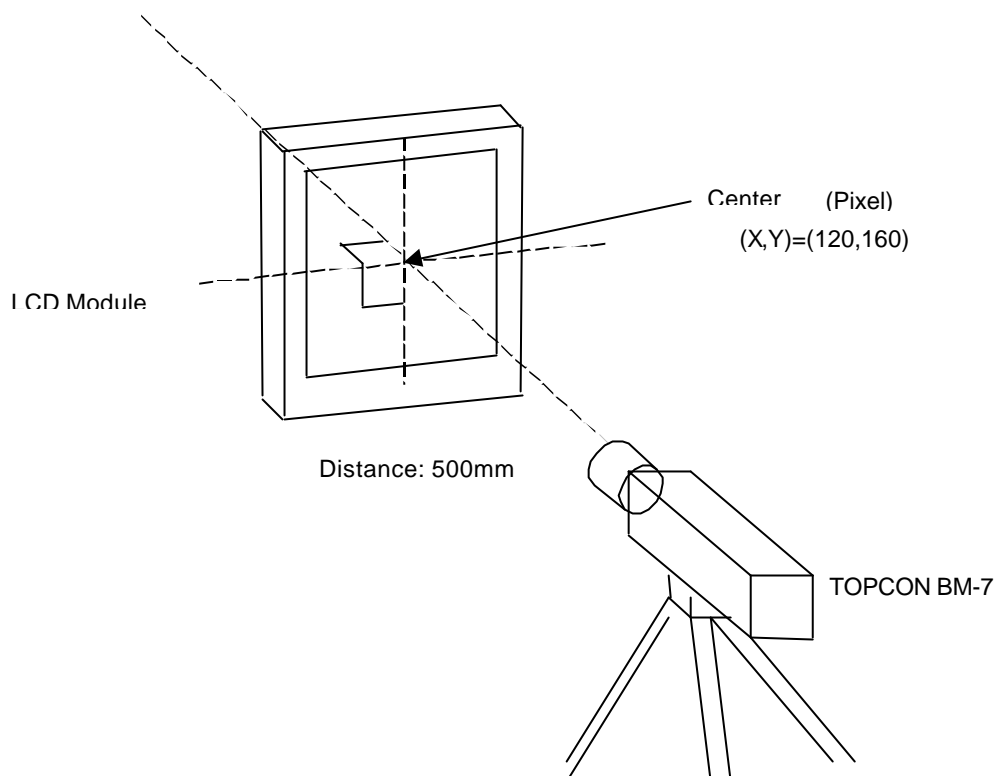

(D4-1b)

Method of Brightness Measurement(Reflective mode)

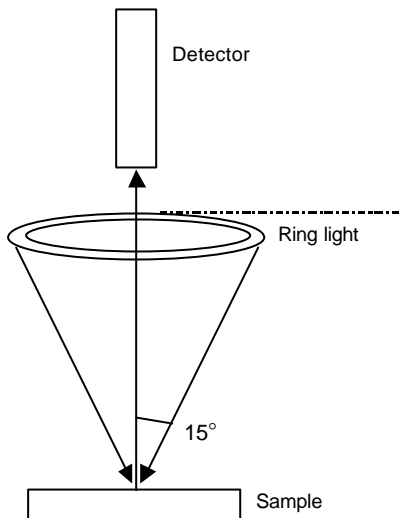

1) Measuring Conditions:

Measuring equipment : Colorimeter: (Yokogawa M&C Corporation)

2) Incident angle

15° Measured angle : 0°

(Angle is defined from normal direction)

3) Light source

Ring light (C light source)

4) Definition of reflectance

Reflection of reflection standard is defined as 100%

5)
$$\frac{\text{Brightness of LCD}}{\text{Brightness of backlight}} \times 100 \quad (\text{ in all white pattern })$$

Method of Contrast Measurement

1) Measuring Device

Colorimeter: (Yokogawa M&C Corporation)

2) Measuring Point

Center of display : Same as Method of Brightness Measurement

3) Method of Measuring

- Set LCD module to $\theta=0^\circ, \phi=0^\circ$
- Change signal voltage to measure maximum Brightness Y1 and minimum brightness Y2.
- Contrast is derived from $CR=Y1/Y2$.

(D4-2)

Definition of Brightness Uniformity

Definition is calculated from the 5 points (S0-S4) on the diagram below.

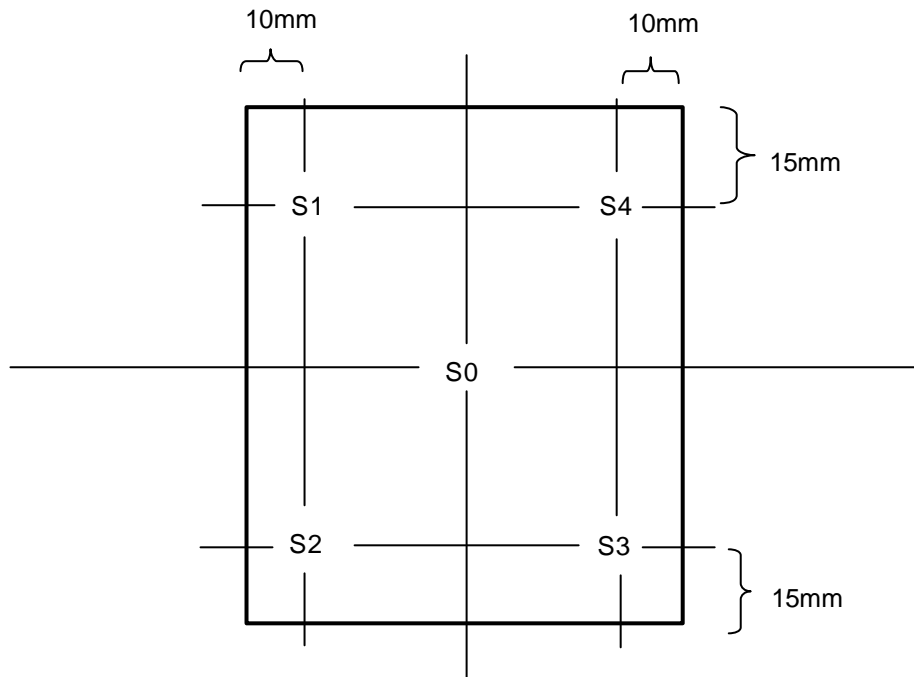

$$\text{Standard value of Brightness Uniformity} = \frac{\text{Minimum value of S1-S4}}{S0}$$

(D4-3)

Method of Viewing Angle Measurement

1) Measuring Device

TOPCON BM-7, Measuring Field: 1°

2) Measuring Point

Center of display: Same as Method of Brightness Measurement

3) Angle of Measuring

θ : An angle vertical to perpendicular line from the viewing direction.

ϕ : An angle horizontal to perpendicular from the viewing direction.

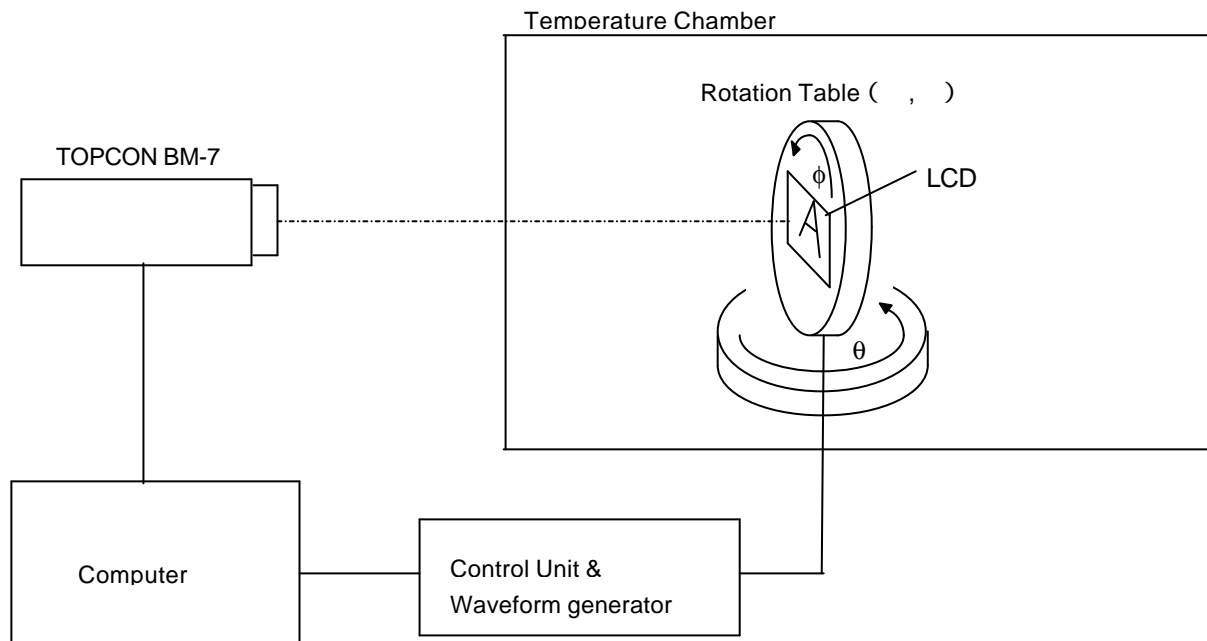

4) Method of Measuring

Set rotation table to $\phi=0^\circ$ and set BM-7 to contrast 10 to measure angle $\pm \theta$ for left and right direction of horizontal viewing angle ϕ . Also set rotation table to $\phi=90^\circ$ and set BM-7 to contrast 10 to measure angle $\pm \theta$ for up and down direction of vertical viewing angle θ .

(D4-4)

Measuring Response Time

(1) Measuring Device

TOPCON BM-7 , Measuring Field : 1°

Tektronix Digital Oscilloscope

(2) Measuring Point

Center of display, same as Method of Brightness Measurement

(3) Method of Measuring

- Set LCD panel to $\theta=0^\circ$, and $\phi=0^\circ$.
- Input white→black→white to display by switching signal voltage.
- If the luminance is 0% and 100% immediately before the change of signal voltage, then τ is optical response time during the change from 90% to 10% immediately after rise of signal voltage, and τ_d is optical response time during the change from 10% to 90% immediately after decay of signal voltage.

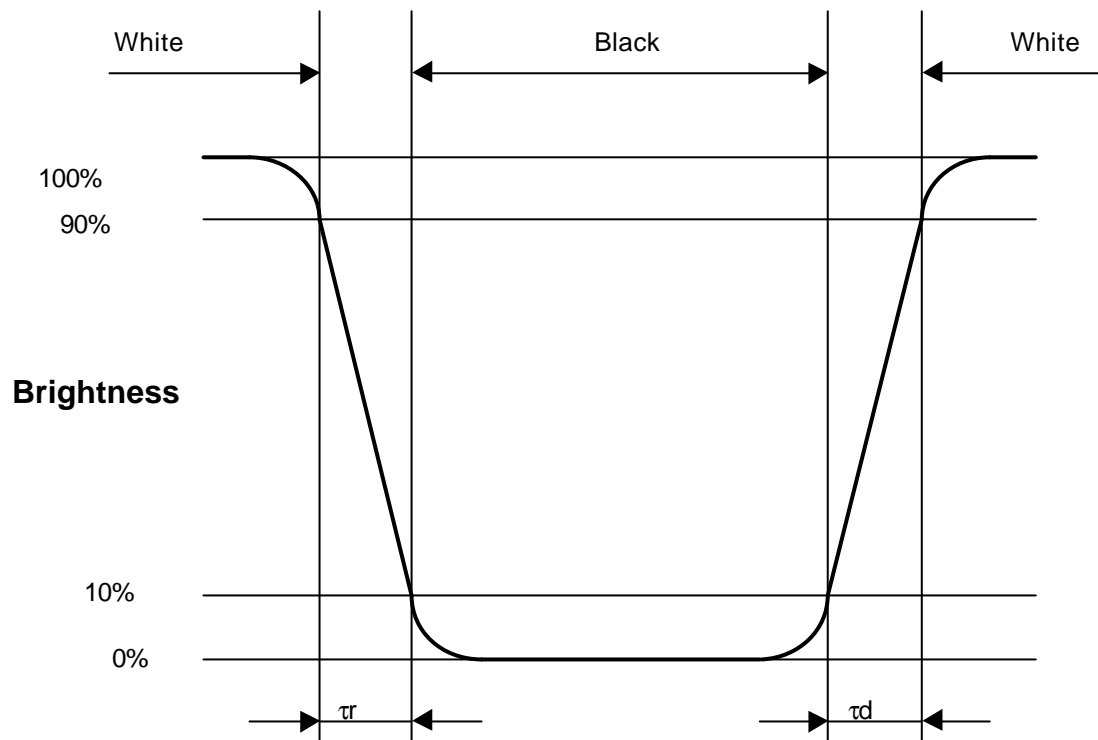

5. I/O Terminal

5.1.Pin Assignment

No.	Symbol	Level	Function	I/O
1	VL1	-	Power Supply for LED (High Voltage)	I
2	NC	-	No Connection	-
3	VL2	-	Power Supply for LED (Low Voltage)	I
4	V _{GL}	-	Power Supply of Gate Drive(Low Level)	I
5	VDDD	-	Power Supply of Digital	I
6	DGND	-	Ground(Digital)	I
7	NC	-	No Connection	-
8	DGND	H / L	Ground(Digital)	I
9	HD	H / L	Horizontal Sync Signal	I
10	U/L	H / L	Selection for Vertical Scanning Direction	I
11	NC	-	No Connection	-
12	V _{GH}	-	Power Supply of Gate Drive(High Level)	I
13	VCOM	H / L	Common Electrode Driving Signal	I
14	DGND	-	Ground(Digital)	I
15	VD	H / L	Vertical Sync Signal	I
16	DGND	-	Ground(Digital)	I
17	VDDA	-	Power Supply(Analog)	I
18	L/R	H / L	Selection for Horizontal Scanning Direction	I
19	RESET	H / L	Hardware Global Reset. Low Active.	I
20	POL	H / L	Polarity Control Signal for Common Inv.	O
21	DGND	-	Ground(Digital)	I
22	B5	H / L	Blue Data Signal(MSB)	I
23	B4	H / L	Blue Data Signal	I
24	B3	H / L	Blue Data Signal	I
25	B2	H / L	Blue Data Signal	I
26	B1	H / L	Blue Data Signal	I
27	B0	H / L	Blue Data Signal(LSB)	I
28	DENA	H / L	Data Enable Signal	I
29	DGND	-	Ground(Digital)	I
30	NC	-	No Connection	-
31	GND	-	Ground	I
32	DCLK	H / L	Data Sampling Clock	I
33	DGND	-	Ground(Digital)	I
34	G5	H / L	Green Data Signal(MSB)	I
35	G4	H / L	Green Data Signal	I

36	G3	H / L	Green Data Signal	I
37	G2	H / L	Green Data Signal	I
38	G1	H / L	Green Data Signal	I
39	G0	H / L	Green Data Signal(LSB)	I
40	DGND	-	Ground(Digital)	I
41	R5	H / L	Red Data Signal(MSB)	I
42	R4	H / L	Red Data Signal	I
43	R3	H / L	Red Data Signal	I
44	R2	H / L	Red Data Signal	I
45	R1	H / L	Red Data Signal	I
46	R0	H / L	Red Data Signal(LSB)	I
47	AGND	-	Ground(Analog)	I
48	NC	-	No Connection	-
49	DGND	-	Ground(Digital)	I
50	DGND	-	Ground(Digital)	I

RecommendationCN : FH12A-50S-0.5SH(HIROSE)

5.2. Gray Scale Table for TFT

Input signals Basic Display Colors and Gray Scale of each Color

Colors & Gray	Data Signal																		
	Gray	R0	R1	R2	R3	R4	R5	G0	G1	G2	G3	G4	G5	B0	B1	B2	B3	B4	B5
Black	-	0	0	0	0	0	0	0	0	0	0	0	0	0	0	0	0	0	0
Blue	-	0	0	0	0	0	0	0	0	0	0	0	0	1	1	1	1	1	1
Green	-	0	0	0	0	0	0	1	1	1	1	1	1	0	0	0	0	0	0
Cyan	-	0	0	0	0	0	0	1	1	1	1	1	1	1	1	1	1	1	1
Red	-	1	1	1	1	1	1	0	0	0	0	0	0	0	0	0	0	0	0
Magenta	-	1	1	1	1	1	1	0	0	0	0	0	0	1	1	1	1	1	1
Yellow	-	1	1	1	1	1	1	1	1	1	1	1	1	0	0	0	0	0	0
White	-	1	1	1	1	1	1	1	1	1	1	1	1	1	1	1	1	1	1
RED	Black	GS0	0	0	0	0	0	0	0	0	0	0	0	0	0	0	0	0	0
	↑	GS1	1	0	0	0	0	0	0	0	0	0	0	0	0	0	0	0	0
	Darker	GS2	0	1	0	0	0	0	0	0	0	0	0	0	0	0	0	0	0
	↑	↓				↓					↓						↓		
	↓	↓				↓					↓						↓		
	Brighter	GS61	1	0	1	1	1	1	0	0	0	0	0	0	0	0	0	0	0
	↓	GS62	0	1	1	1	1	1	0	0	0	0	0	0	0	0	0	0	0
Red	GS63	1	1	1	1	1	1	0	0	0	0	0	0	0	0	0	0	0	
GREEN	Black	GS0	0	0	0	0	0	0	0	0	0	0	0	0	0	0	0	0	0
	↑	GS1	0	0	0	0	0	0	1	0	0	0	0	0	0	0	0	0	0
	Darker	GS2	0	0	0	0	0	0	0	1	0	0	0	0	0	0	0	0	0
	↑	↓				↓					↓						↓		
	↓	↓				↓					↓						↓		
	Brighter	GS61	0	0	0	0	0	0	1	0	1	1	1	1	0	0	0	0	0
	↓	GS62	0	0	0	0	0	0	0	1	1	1	1	1	0	0	0	0	0
Green	GS63	0	0	0	0	0	0	1	1	1	1	1	1	0	0	0	0	0	
BLUE	Black	GS0	0	0	0	0	0	0	0	0	0	0	0	0	0	0	0	0	0
	↑	GS1	0	0	0	0	0	0	0	0	0	0	0	1	0	0	0	0	0
	Darker	GS2	0	0	0	0	0	0	0	0	0	0	0	0	1	0	0	0	0
	↑	↓				↓					↓						↓		
	↓	↓				↓					↓						↓		
	Brighter	GS61	0	0	0	0	0	0	0	0	0	0	0	0	1	0	1	1	1
	↓	GS62	0	0	0	0	0	0	0	0	0	0	0	0	0	1	1	1	1
Blue	GS63	0	0	0	0	0	0	0	0	0	0	0	0	1	1	1	1	1	

0:Low Voltage 1:High Voltage each primary color can be displayed in 64 gray scales from 6 bit data signals. According to the coordination of a total 18 bit data signals, the 262,144 color display can be achieved on screen.

5.3. Block Diagram

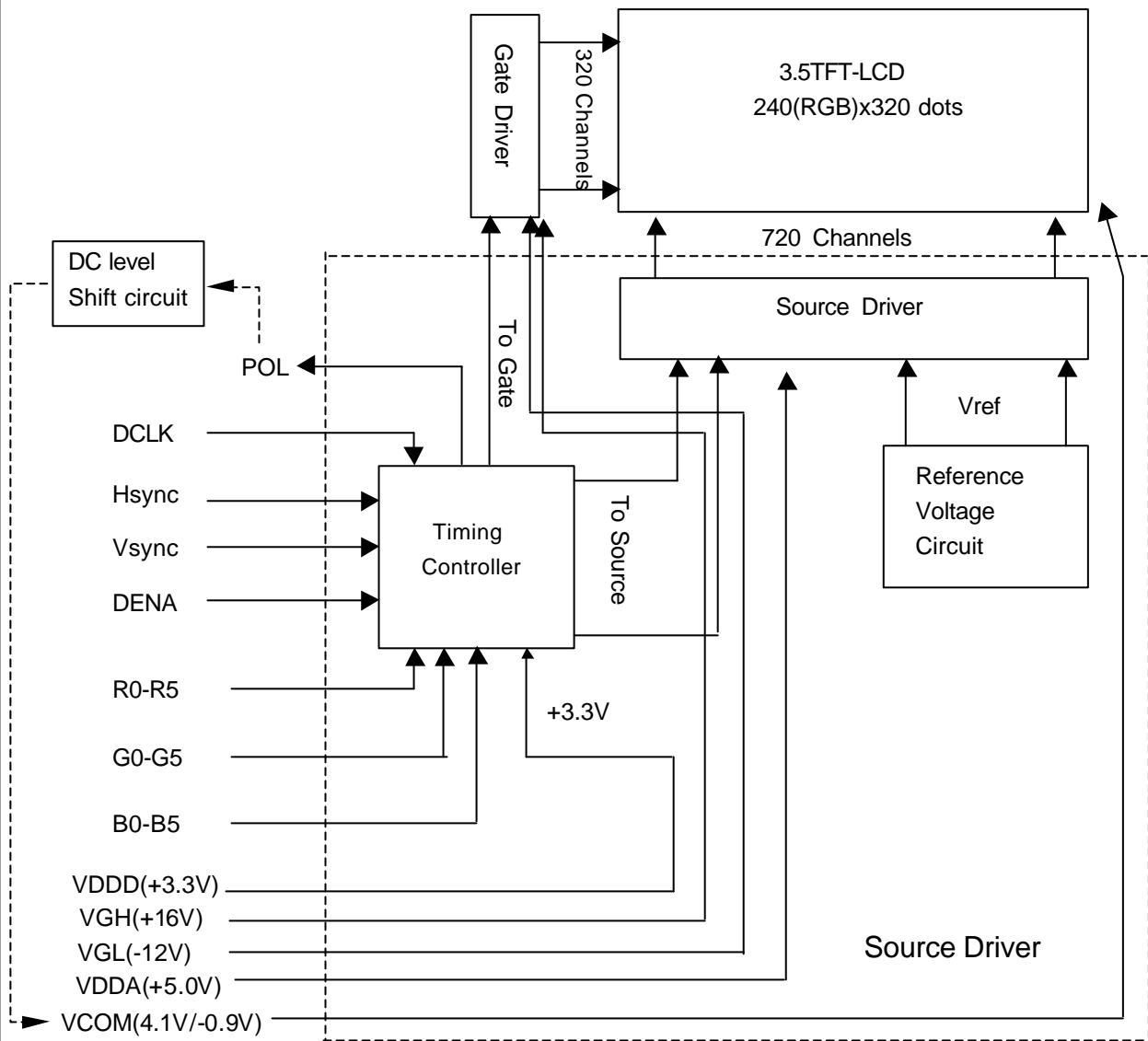

6. Test

6.1. Mechanical and Environmental Test

No.	Parameter	Conditions
1	High Temperature Storage Test	Ta=+70°C, 240hrs
2	Low Temperature Storage Test	Ta=-30°C, 240hrs
3	High Temperature and High Humidity Operating Test	Ta=+40°C, 90%RH, 240hrs (But no condensation of dew)
4	High Temperature Operating Test	Ta=+70°C, 240hrs
5	Low Temperature Operating Test	Ta=-20°C, 240hrs
6	Electro Static Discharge Test	±200V, 200pF(0Ω) to Terminals(Contact) (1 time for each terminal) ±8kV, 150pF(330Ω) to Housing bezel or TP(Contact) ±15kV, 150pF(330Ω) to Housing bezel or TP(in Air))
7	Shock Test	980m/s ² , 6ms ±X, ±Y, ±Z 3 times for each direction
8	Vibration Test	Frequency range : 10~55Hz Stroke : 1.5mm Sweep : 10~55Hz X, Y, Z 2 hours for each direction (total 6 hours)
9	Heat Shock Test	Ta=-25°C(1h)~+70°C(1h) / 5 cycles
10	FPC Bending Test	Bending 30 times by bending radius R0.6mm and angle=90°(LCD FPC)

7. Appearance Standards

7.1. Extraneous Substances, Scratches, Dents

Externals defect which does not shine (touch panel [including icon area]&LCD panel total)

Length : L(mm), Average diameter : D(mm)

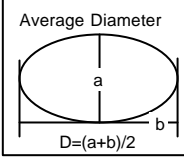
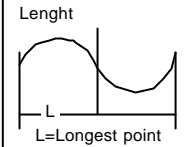
	Inspection standards			Check pattern	
	No count	Count	NG		
Black or White spots	$D < 0.15$	$0.15 \leq D \leq 0.3, N \leq 2$	$D > 0.3$	white/black	
Lint	$L < 0.15$	$0.15 \leq L \leq 3.0, N \leq 2$	$L > 3.0$	black	
Scratches	$L < 2.0$	$2.0 \leq L \leq 5.0, N \leq 3$	$L > 5.0$	black	
Dent or Bubble	$D < 0.15$	$0.15 \leq D \leq 0.3, N \leq 3$	$D > 0.3$	black	

*Please refer to inspection conditions section (Shown Below) for the external inspection conditions.

Inspection conditions

item	Inspection conditions	
	External lighting source inspection	Black light inspection
Panel Surface Illumination	750 lx (uniform lighting on the panel surface)	TBD (Panel center brightness)
Light Source	Florescent tube	-
Ambient Illumination	300 ~ 700 lx	←
Viewing Distance	350mm ± 50 mm	←
Direction of Lighting	Set light tube without reflection on the panel surface	-
Viewing Angle	The surface of the Module and the eyes of the inspector shall be 90 ± 5 degrees.	←
How to use ND filter	Use ND filter close to eyes (fig 1)	Use ND filter open to eyes(fig2)
Check pattern(Bright dot)	Black picture position	←
Check pattern(Black dot)	White picture position	←

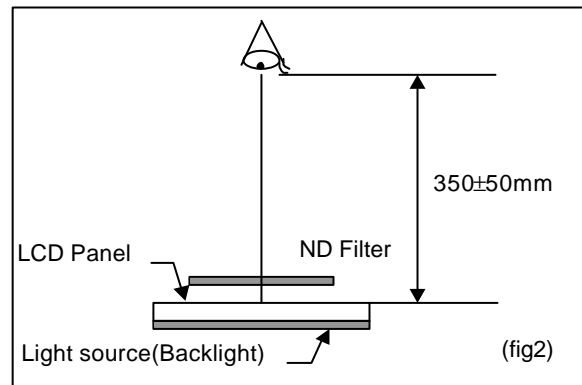
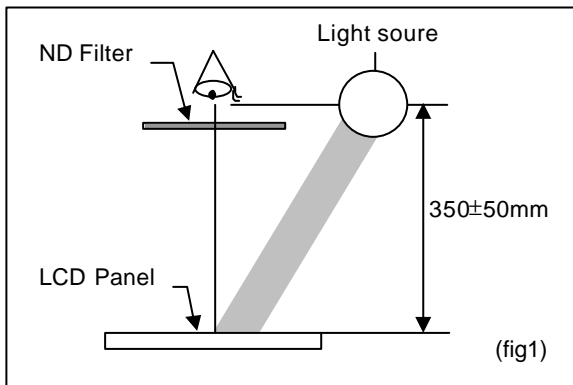

Definition

a) Bright dot

Green/Red/Blue dots : When the MODULE lights, dots appear bright in display at black picture position.

Count : Visible through 5% transparency of filter (Red, Green, Blue)

No count : Not visible through 5% transparency of filter

b) Black dot

Black dots : When the Module lights, dots appear black in display at white picture position.

c) Scratch on the color filter

Count : Visible over the half of a dot

No count : Visible under the half of a dot

d) Scratch on the Black mask

Count : Visible over 50 $\mu\text{m}\phi$

No count : Visible under 50 $\mu\text{m}\phi$

Bright dot

	Zone total(Active area)
Bright dots	3

Total number of defect(Bright dot + Black dot)

	Zone total(Active area)
Total number of defect (Bright dot + Black dot)	6

Defect distance & join

Bright dots distance	5mm min
Bright dots join	nothing
Black dots distance	5mm min
Black dots join(2 dots)	1 (black dot) count
Black dots join(3 dots or more)	nothing

8. Code System of Production Lot

The production lot of module is specified as follows.

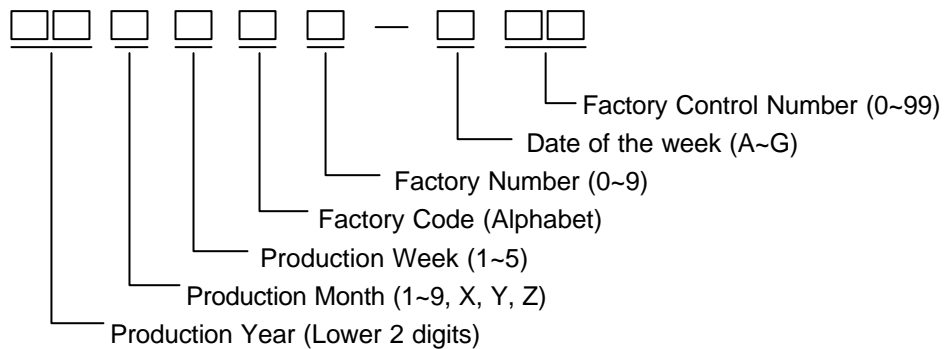

9. Type Number

The type number of module is specified as follows.

T-51963GD035J-MLW-AFN

10. Applying Precautions

Please contact us when questions and/or new problems not specified in this Specifications arise.

11. Precautions Relating Product Handling

The Following precautions will guide you in handling our product correctly.

- 1) Liquid crystal display devices
 1. The liquid crystal display device panel used in the liquid crystal display module is made of plate glass. Avoid any strong mechanical shock. Should the glass break handle it with care.
 2. The polarizer adhering to the surface of the LCD is made of a soft material. Guard against scratching it.
- 2) Care of the liquid crystal display module against static electricity discharge.
 1. When working with the module, be sure to ground your body and any electrical equipment you may be using. We strongly recommend the use of anti static mats (made of rubber), to protect work tables against the hazards of electrical shock.
 2. Avoid the use of work clothing made of synthetic fibers. We recommend cotton clothing or other conductivity-treated fibers.
 3. Slowly and carefully remove the protective film from the LCD module, since this operation can generate static electricity.
- 3) When the LCD module alone must be stored for long periods of time:
 1. Protect the modules from high temperature and humidity.
 2. Keep the modules out of direct sunlight or direct exposure to ultraviolet rays.
 3. Protect the modules from excessive external forces.
- 4) Use the module with a power supply that is equipped with an overcurrent protector circuit, since the module is not provided with this protective feature.
- 5) Do not ingest the LCD fluid itself should it leak out of a damaged LCD module. Should hands or clothing come in contact with LCD fluid, wash immediately with soap.
- 6) Conductivity is not guaranteed for models that use metal holders where solder connections between the metal holder and the PCB are not used. Please contact us to discuss appropriate ways to assure conductivity.
- 7) For models which use CFL:
 1. High voltage of 1000V or greater is applied to the CFL cable connector area. Care should be taken not to touch connection areas to avoid burns.
 2. Protect CFL cables from rubbing against the unit and thus causing the wire jacket to become worn.
 3. The use of CFLs for extended periods of time at low temperatures will significantly shorten their service life.
- 8) For models which use touch panels:
 1. Do not stack up modules since they can be damaged by components on neighboring modules.
 2. Do not place heavy objects on top of the product. This could cause glass breakage.
- 9) For models which use COG, TAB, or COF:
 1. The mechanical strength of the product is low since the IC chip faces out unprotected from the rear. Be sure to protect the rear of the IC chip from external forces.
 2. Given the fact that the rear of the IC chip is left exposed, in order to protect the unit from electrical damage, avoid installation configurations in which the rear of the IC chip runs the risk of making any electrical contact.

10) Models which use flexible cable, heat seal, or TAB:

1. In order to maintain reliability, do not touch or hold by the connector area.
2. Avoid any bending, pulling, or other excessive force, which can result in broken connections.

11) In case of buffer material such as cushion / gasket is assembled into LCD module, it may have an adverse effect on connecting parts (LCD panel-TCP / HEAT SEAL / FPC / etc., PCB-TCP / HEAT SEAL / FPC etc., TCP-HEAT SEAL, TCP-FPC, HEAT SEAL-FPC, etc.) depending on its materials.

Please check and evaluate these materials carefully before use.

12) In case of acrylic plate is attached to front side of LCD panel, cloudiness (very small cracks) can occur on acrylic plate, being influenced by some components generated from polarizer film..

Please check and evaluate those acrylic materials carefully before use.

12. Warranty

This product has been manufactured to your company's specifications as a part for use in your company's general electronic products. It is guaranteed to perform according to delivery specifications. For any other use apart from general electronic equipment, we cannot take responsibility if the product is used in medical devices, nuclear power control equipment, aerospace equipment, fire and security systems, or any other applications in which there is a direct risk to human life and where extremely high levels of reliability are required. If the product is to be used in any of the above applications, we will need to enter into a separate product liability agreement.

1. We cannot accept responsibility for any defect, which may arise from additional manufacturing of the product (including disassembly and reassembly), after product delivery.
2. We cannot accept responsibility for any defect, which may arise after the application of strong external force to the product.
3. We cannot accept responsibility for any defect, which may arise due to the application of static electricity after the product has passed your company's acceptance inspection procedures.
4. When the product is in CFL models, CFL service life and brightness will vary according to the performance of the inverter used, leaks, etc. We cannot accept responsibility for product performance, reliability, or defect, which may arise.
5. We cannot accept responsibility for intellectual property of a third party, which may arise through the application of our product to your assembly with exception to those issues relating directly to the structure or method of manufacturing of our product.
6. Optrex will not be held responsible for any quality guarantee issue for defect products judged as Optrex-origin longer than 2 (two) years from Optrex production or 1(one) year from Optrex, Optrex America, Optrex Europe delivery which ever comes later.