

ARCNET® Twisted Pair and Coaxial Compatible High Impedance Transceiver HIT™

FEATURES

- ARCNET on Telephone Twisted Pair or Coaxial Cable
- Drives Shielded and Unshielded Twisted Pair Cable or Coaxial Cable
- Compatible with Existing ARCNET Installations
- Direct Replacement for the ARCNET HYC9058 High Impedance Transceiver
- Pin Compatible with the ARCNET HYC9068 LAN Driver with the Addition of a Single Terminating Resistor
- Supports Star, Bus, and Daisy Chained Configurations
- Enhanced Built-in Filters for Reduced EMI
- Twenty Pin Single In-Line Package
- Straight or Right Angle Lead Frame
- New Reduced Size

GENERAL DESCRIPTION

The HYC9088A Twisted Pair and Coaxial Compatible High Impedance Transceiver (HIT) is a hybrid module that interfaces an ARCNET Local Area Network controller to telephone twisted pair or coaxial cable. The HIT interfaces directly with Standard Microsystems Corporation's ARCNET LAN controllers operating at 2.5 Mbps and connects to a variety of shielded and unshielded twisted pair or coaxial cables via an on-board transformer. The network topologies supported by the HIT are daisy chain, star, and bus configurations.

During data transmission, the HIT converts the digital pulse information provided by the LAN controller into analog signals and drives them onto the cable. The transmitted signals are filtered to eliminate undesirable frequencies. The receiver section of the HYC9088A

identifies dipulse signals on the cable and converts them into TTL signals to be supplied to the LAN controller.

The HIT supports ARCNET's Dipulse Encoding Scheme and, is 100% compatible with all existing coax-based ARCNET networks. This provides an ARCNET network designer with flexibility to easily combine coax and twisted pair cabling.

The HYC9088A is pin compatible with the HYC9058 High Impedance Transceiver and is pin compatible with the HYC9068 LAN Driver with the addition of a single terminating resistor.

ARCNET is a registered trademark of Datapoint Corporation
HIT is a trademark of Standard Microsystems Corporation.

TABLE OF CONTENTS

FEATURES	1
GENERAL DESCRIPTION	1
PIN CONFIGURATION	3
DESCRIPTION OF PIN FUNCTIONS	4
FUNCTIONAL DESCRIPTION	5
APPLICATION INFORMATION	5
OPERATIONAL DESCRIPTION	11
MAXIMUM GUARANTEED RATINGS	11
DC ELECTRICAL CHARACTERISTICS	11

PIN CONFIGURATION

Pin 1 Designator

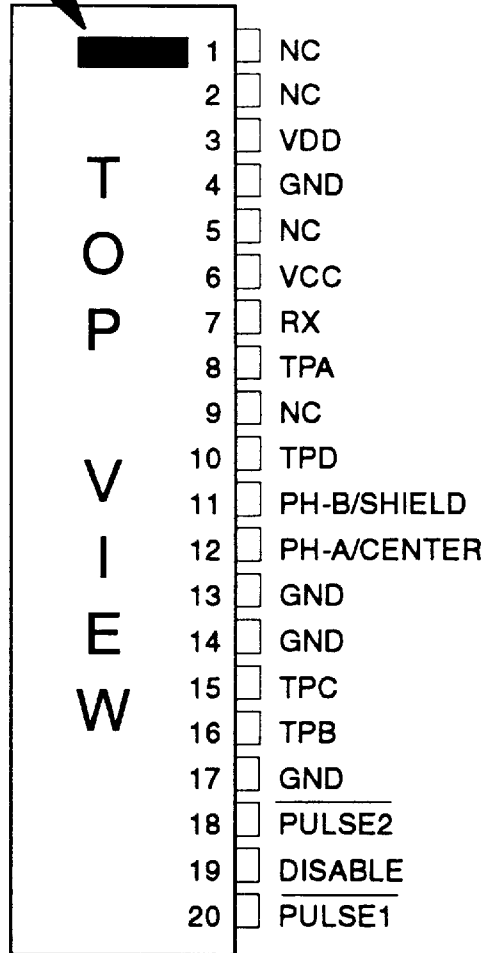

PACKAGE: 20-Pin SIP

Ordering Information:

HYC9088AR for right angle lead frame

HYC9088AS for straight lead frame

DESCRIPTION OF PIN FUNCTIONS

PIN NO.	NAME	SYMBOL	DESCRIPTION
1, 2, 5, 9	No Connect	NC	Not used. Make no connection to these pins.
3	Power Supply	VDD	-5 Volts power supply.
4, 13, 14, 17	Ground	GND	Ground.
6	Power Supply	VCC	+ 5 Volts power supply.
7	Receive Data	RX	Output. This signal carries the TTL receive pulse information to the ARCNET LAN Controller Device.
8, 16, 15, 10	Test Points	TPA, TPB, TPC, TPD	Test points. Make no connection to these pins.
11	Phase-B/ Shield	PH-B/ SHIELD	Output. Connect this signal to Twisted Pair Connector pin 3 or the shield of the coaxial cable.
12	Phase-A/ Center	PH-A/ CENTER	Output. Connect this signal to Twisted Pair Connector pin 2 or the center of the coaxial cable.
18	Pulse 2	PULSE2	Input. This signal is supplied by the ARCNET LAN Controller Device.
19	Disable TX	DISABLE TRANSMIT	Input. A high level on this signal disables the transmit section of the HYC9088A. It is normally connected to ground.
20	Pulse 1	PULSE1	Input. This signal is supplied by the ARCNET LAN Controller Device.

FUNCTIONAL DESCRIPTION

The HIT integrates a host of discrete components into a hybrid module and provides the Local Area Network designer with space and cost savings as well as the enhanced reliability of a single component. Since the HIT is a high impedance transceiver, it does not disturb the characteristic impedance of the cable used to interconnect ARCNET nodes. The two far ends of the twisted pair cable must be terminated using terminating resistors equal to the characteristic impedance of the cable. The HIT is made up of a transmit section and a receive section. (Please refer to Figure 1).

Transmit Section

The ARCNET LAN controller transmits a logic "1" by generating two 100 ns non-overlapping negative pulses, PULSE1 and PULSE2. These signals are converted by the HIT into a 200 ns dipulse signal. The HIT shapes the 200 ns signal into a single cycle of a 5 MHz sine-wave and filters higher frequency components. The dipulse signal is then transformer-coupled onto the cable and has a minimum voltage output of 16 Volts peak-to-peak. The exact output voltage of the HIT will vary depending on the

characteristic impedance of the cable used. The driving circuitry of the HIT has been designed to present a high impedance on the cable in order to minimize loading.

The DISABLE input of the HYC9088A can be used to prevent the device from transmitting. During normal operation, the DISABLE input is tied to ground.

Receiver Section

The received dipulse signal from the cable is electrically isolated through the use of a transformer. This signal is passed through a filter which eliminates out of band noise. The receive signal is then fed to a comparator which converts it into a TTL signal ready to be applied to the LAN controller chip. The comparator compares the received signal to an internal voltage threshold to distinguish noise from real signal. This threshold level may be adjusted externally by pin 5 in order to set the receive sensitivity of the comparator. For normal operation, this signal is connected to a 1K Ω resistor to ground.

APPLICATION INFORMATION

Small Twisted Pair Networks

The HIT eliminates the need for active hubs in small ARCNET networks. For example, a ten node ARCNET network can be constructed by connecting ten HITs using a daisy-chained or bus configuration (see Figure 2). Note that both extremes of the cable must be terminated with a resistor which matches the characteristic impedance of the Twisted Pair Cable. For the cable types specified in Table 1, the maximum length of the twisted pair cable recommended is 400 feet.

Small Coax Network

No active hub is required for an ARCNET network consisting of eight nodes or less using the HYC9088A for coax cable (See Figure 2A). Both ends of the cable must be terminated with a resistor which matches the characteristic impedance of the coax cable. For the RG62 cable specified in Table 1, the maximum length of the coax cable recommended is 1000 feet.

Combination of Twisted Pair and Coax Networks

A Two-Port Link is used to combine twisted pair network and a coax network. A Two-Port Link has a coax connector on one side and two modular jacks on the other and contains the proper impedance-matching circuitry. Refer to Figure 3 for an illustration of a twisted pair network combined with a coaxial network.

Proper Connection for Twisted Pair

Each twisted pair compatible ARCNET node would typically have two RJ-11 modular

connectors mounted on the node card (refer to Figure 4). PHASE A should be connected to pin 2 of the connectors and PHASE B to pin 3. A twisted pair segment would have an RJ-11 modular jack on each end (see Figure 5). Please note that the suggested numbering scheme of the modular jack shown in Figure 5 may not be consistent with that found on some manufacturers' products. Please ensure consistent connection of Phase A and Phase B signals throughout the network to avoid the reception of erroneous data.

Table 1 - Specifications for Cabling

PARAMETER	VALUE FOR COAX	VALUE FOR TWISTED PAIR
Wiring	RG62	Solid Copper 22, 24, or 26 AWG
Number of Twists/Foot	N/A	2 min.
DC Resistance	3.4 Ohms/1000 ft.	28.6 Ohms/1000 ft. max.
Characteristic Impedance	93 Ohms at 1 MHz	105 Ohms \pm 20% at 1 MHz
Maximum Attenuation	5.5 dB/1000 ft. at 5 MHz	16.0 dB/1000 ft. at 5 MHz

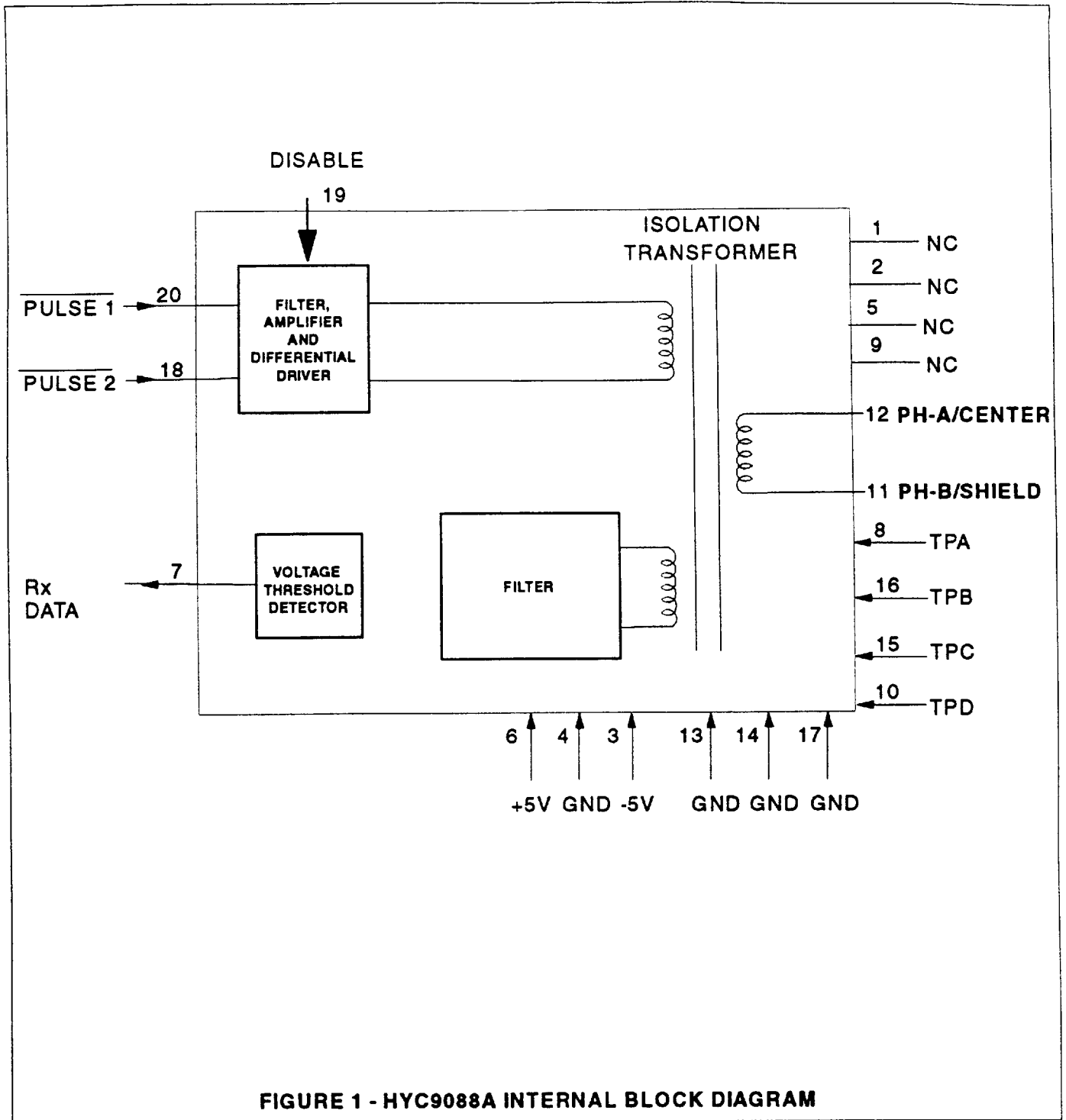

FIGURE 1 - HYC9088A INTERNAL BLOCK DIAGRAM

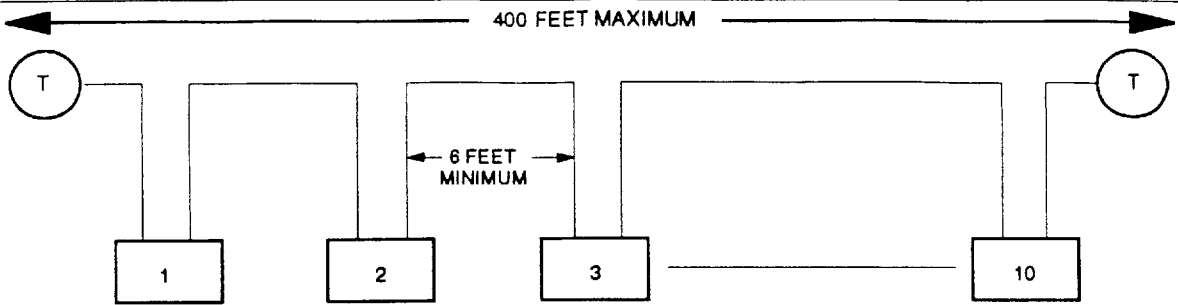

FIGURE 2 - TYPICAL SMALL TWISTED PAIR ARCNET NETWORK USING Hyc9088A

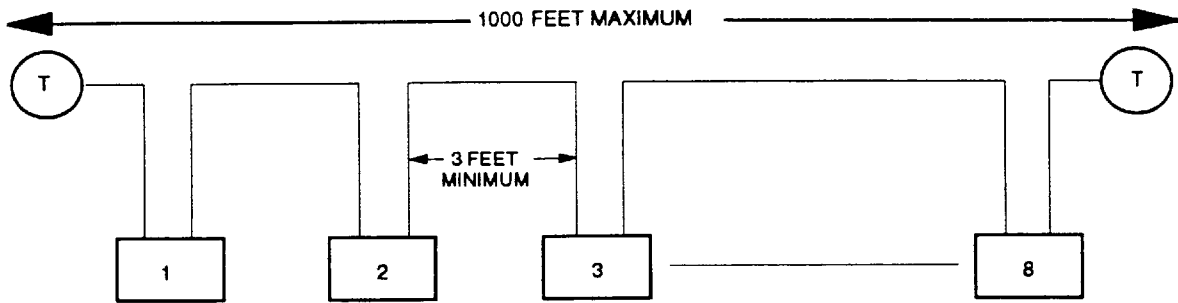
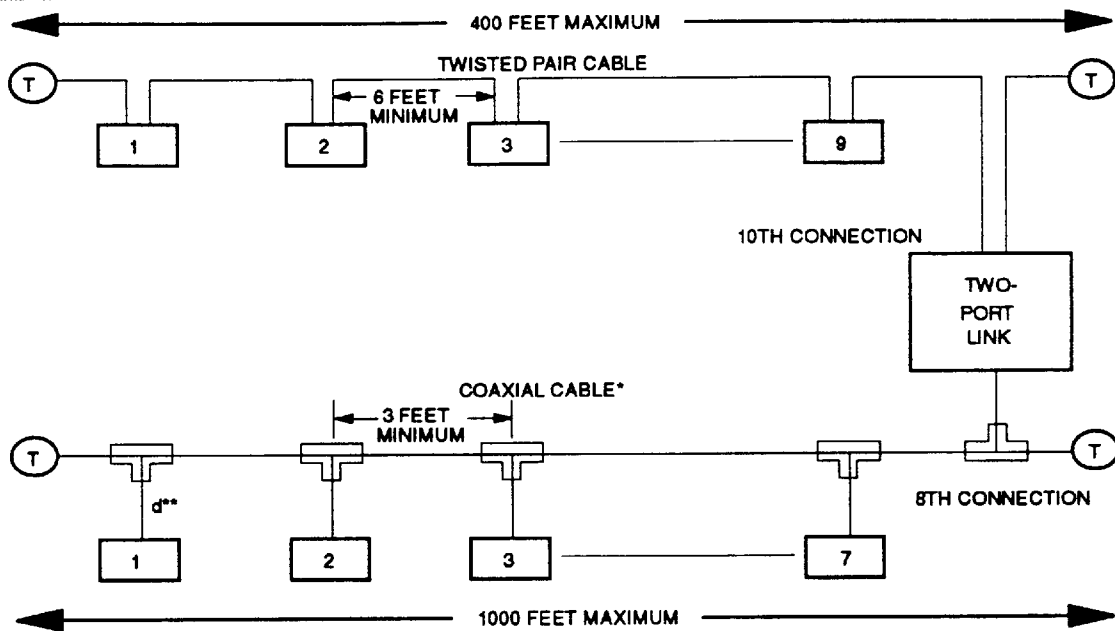

FIGURE 2A - TYPICAL SMALL COAX ARCNET NETWORK USING Hyc9088A



*For more detail, see TN 7-1

**Stub length should be kept as short as possible

FIGURE 3 - TYPICAL COMBINATION OF TWISTED PAIR AND COAXIAL CABLE ON AN ARCNET NETWORK USING Hyc9088A

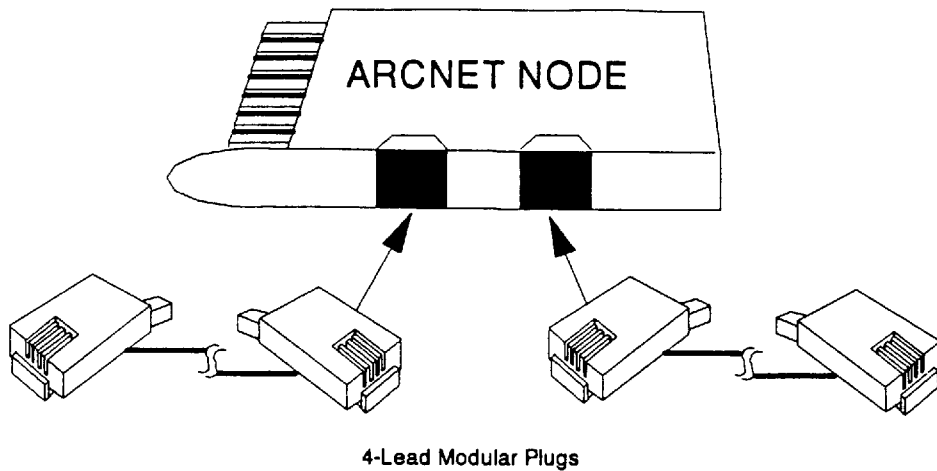
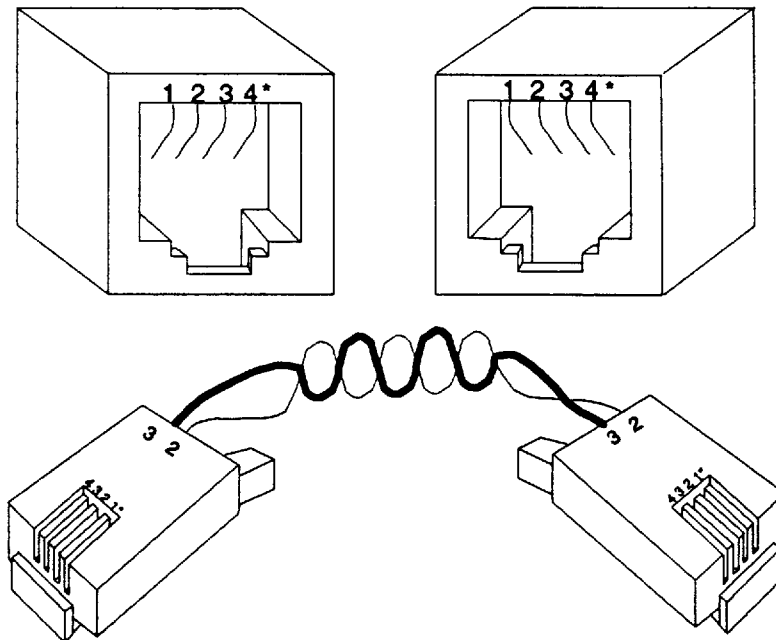
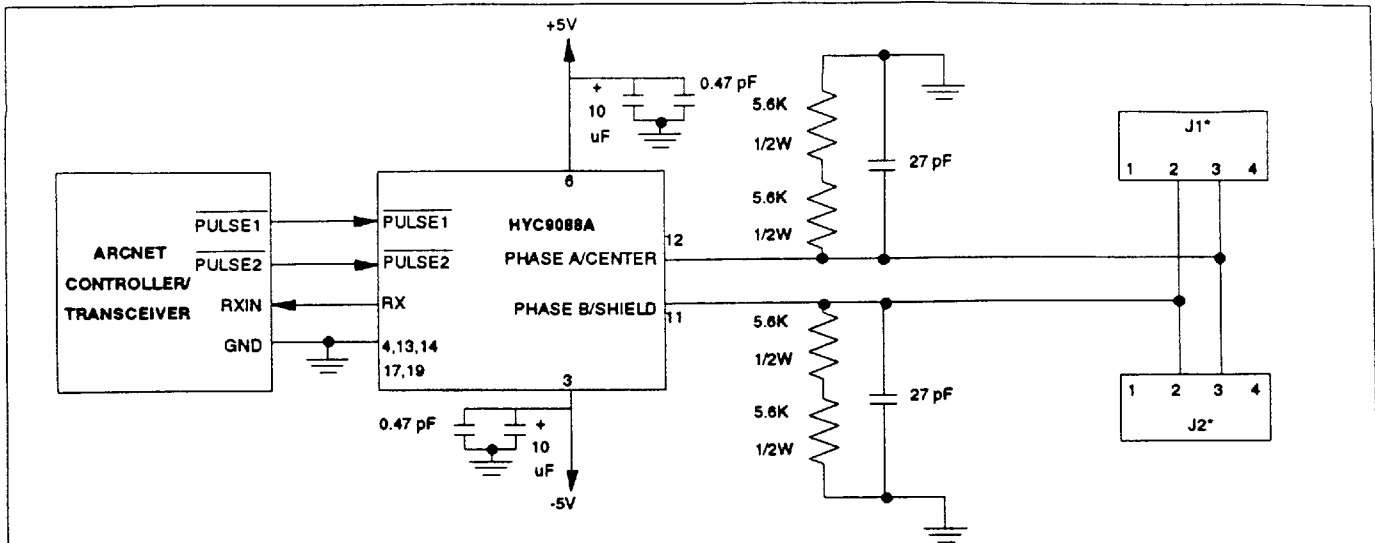

FIGURE 4 - RJ-11 CONNECTORS ON NODE CARD



*Please note that the numbering scheme of the modular jack shown above is the opposite of that found on Standard Microsystems' Systems Products Division's boards and hubs. Please adhere to one scheme and ensure consistent connection of Phase A and Phase B signals throughout the network for proper operation.

FIGURE 5 - PHASE RELATIONSHIP ON TWISTED PAIR SEGMENT AND RJ-11 CONNECTOR PINOUT



*Please see note in Figure 5 regarding the numbering scheme of the modular jack.

FIGURE 6 - TYPICAL HYC9088A INTERCONNECT FOR TWISTED PAIR CABLE

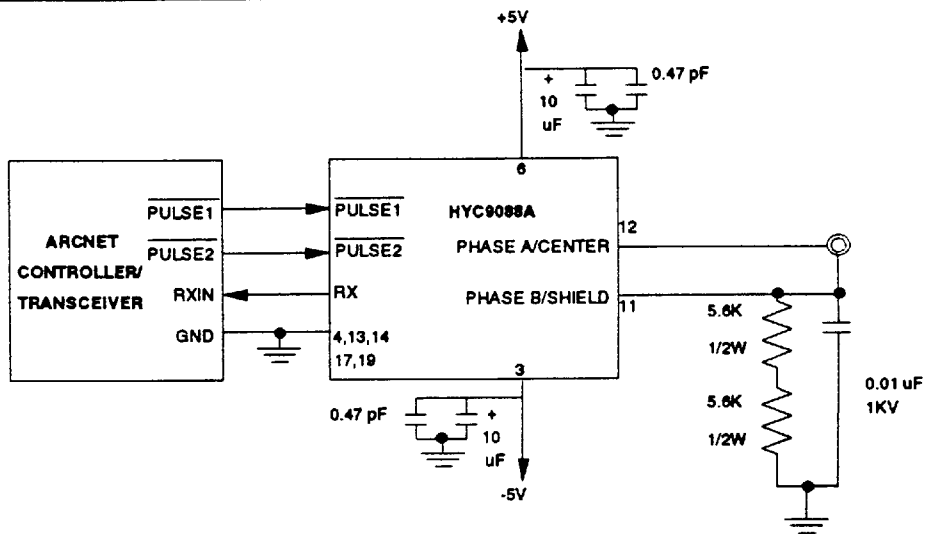

FIGURE 7 - TYPICAL HYC9088A INTERCONNECT FOR COAXIAL CABLE

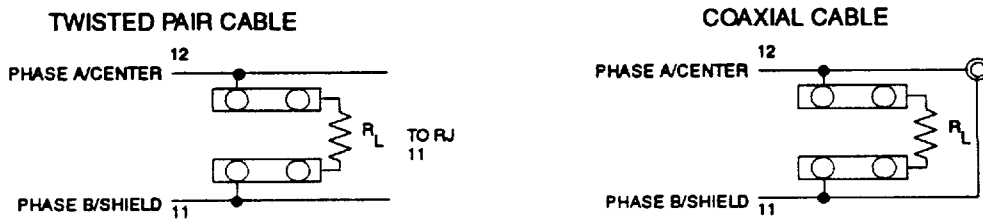

FIGURE 8 - DESCRIPTION OF TERMINATOR WIRING

OPERATIONAL DESCRIPTION

MAXIMUM GUARANTEED RATINGS*

Operating Temperature Range	0°C to +70°C
Storage Temperature Range	-55° to +150°C
Lead Temperature Range (soldering, 10 seconds)	+325°C
Positive Voltage on any pin, with respect to Ground	$V_{cc} + 0.3V$
Negative Voltage on any pin, except V_{DD} , with respect to Ground	-0.3V

*Stresses above those listed above could cause permanent damage to the device. This is a stress rating only and functional operation of the device at any other condition above those indicated in the operation sections of this specification is not implied.

Note: When powering this device from laboratory or system power supplies, it is important that the Absolute Maximum Ratings not be exceeded or device failure can result. Some power supplies exhibit voltage spikes on their outputs when the AC power is switched on or off. In addition, voltage transients on the AC power line may appear on the DC output. If this possibility exists, it is suggested that a clamp circuit be used.

DC ELECTRICAL CHARACTERISTICS ($T_A = 0^\circ C$ to $70^\circ C$, $V_{CC2} = +5.0 V \pm 5\%$, $V_{DD} = -5.0V \pm 5\%$)

PARAMETER	SYMBOL	MIN	TYP	MAX	UNITS	COMMENTS
Low Input Voltage	V_{IL}			0.8	V	$I_{IL} = -0.8 \text{ mA}$
High Input Voltage	V_{IH}	2.0			V	$I_{IH} = +0.2 \text{ mA}$
Received Signal Amplitude	V_R	6.0 3.0			V_{P-P} V_{O-P}	
Low Output Voltage	V_{OL}			0.4	V	One TTL Load
High Output Voltage	V_{OH}	2.4			V	One TTL Load
Transformer Output	V_T	16 8	20 10		V_{P-P} V_{O-P}	$Z_{chr} \text{ cable} = 120\Omega$ or 93Ω
Cable Noise Amplitude	V_C			4	V_{P-P}	
V_{CC} Supply Current	I_{CC}		190	285	mA	
V_{DD} Supply Current	I_{DD}		180	270	mA	
Pulse Width, Pulse 1, 2	PW		100		nS	

Shorting the transformer output may cause permanent damage to the device.

HYC9088R for Right Angle Lead Frame
 HYC9088S for Straight Lead Frame

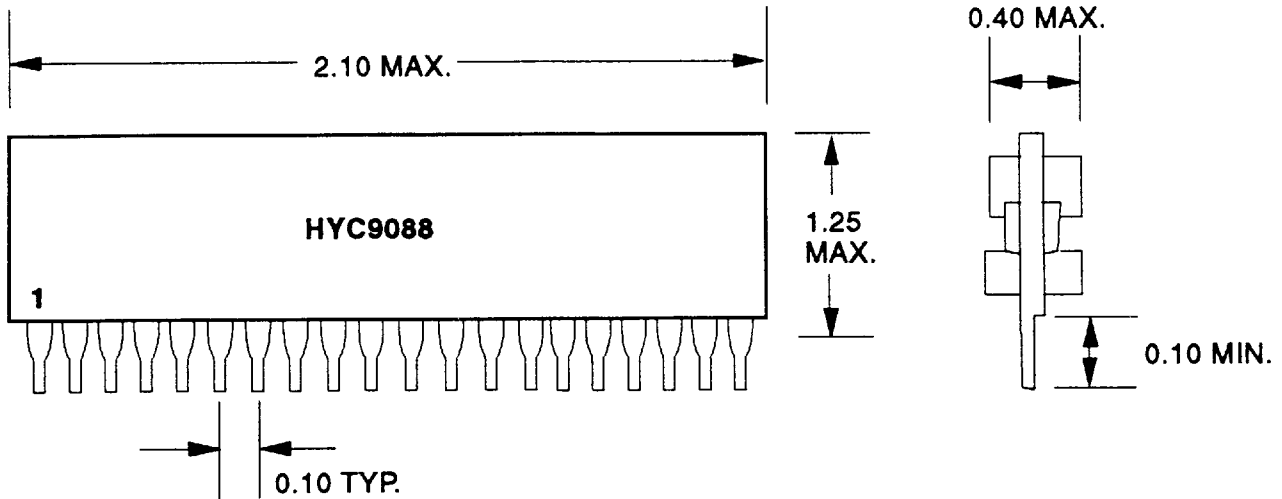

FIGURE 9 - 20-PIN SIP PACKAGE DIMENSIONS

©1994 STANDARD MICROSYSTEMS
 CORP.

**STANDARD MICROSYSTEMS
 CORPORATION**
 COMPONENT
 PRODUCTS DIVISION

Circuit diagrams utilizing SMC products are included as a means of illustrating typical applications; consequently complete information sufficient for construction purposes is not necessarily given. The information has been carefully checked and is believed to be entirely reliable. However, no responsibility is assumed for inaccuracies. Furthermore, such information does not convey to the purchaser of the semiconductor devices described any licenses under the patent rights of SMC or others. SMC reserves the right to make changes at any time in order to improve design and supply the best product possible.

Rev. 3/10/94

8564686 0009156 296

42824

12