

# FIP<sup>®</sup> Products Selection Guide

August 1994

© 1994 NEC Electronics Inc. All rights reserved.

Printed in U.S.A.

FIP is a registered trademark of NEC Corporation.

## NEC's FIP Panels Perform the Crucial Role of Conveying Accurate Information

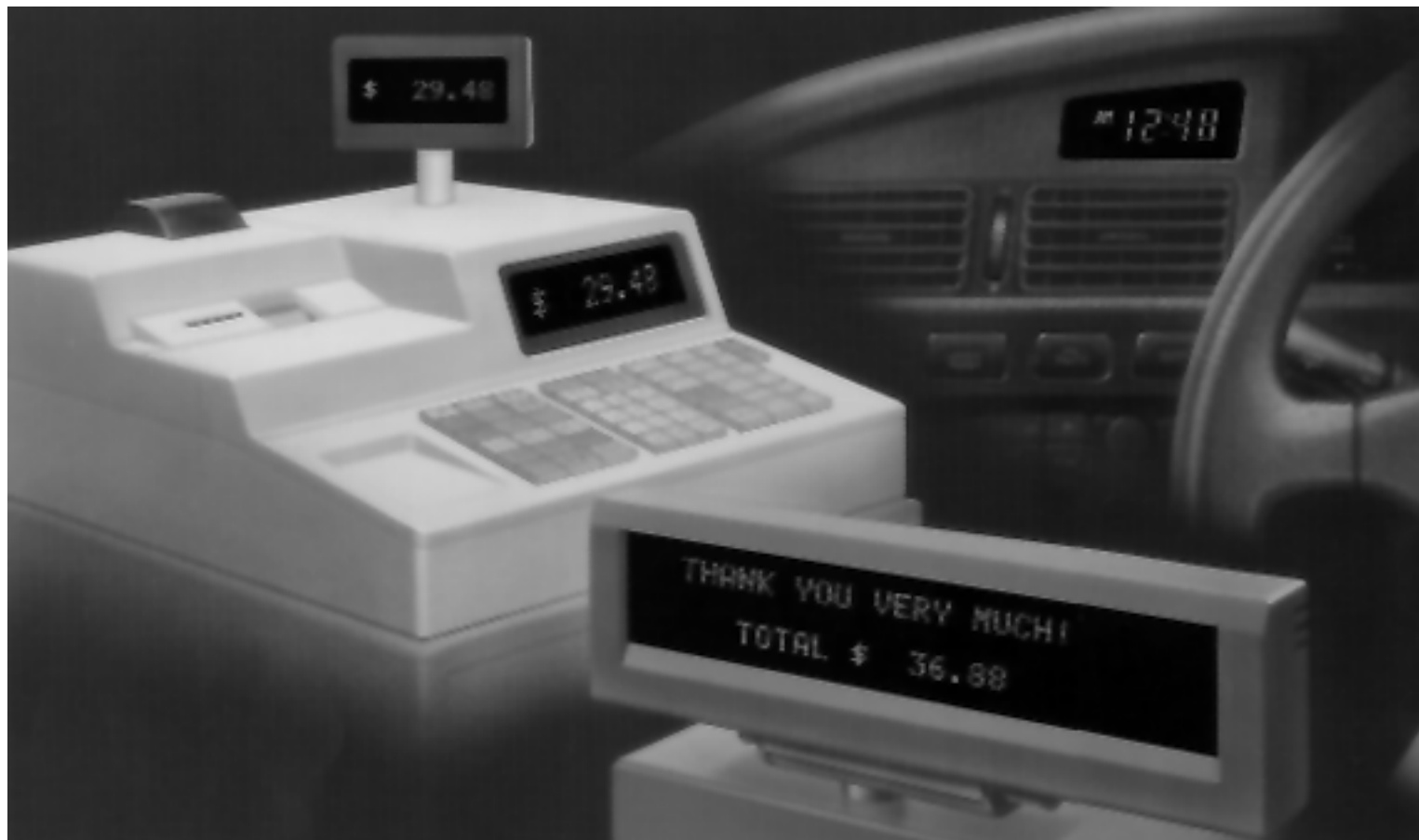



## Features

---

- Compact design
- Low-power operation
- MOS LSI-compatible
- Multicolor display options
- Long life
- High reliability
- Standard or custom design

## Major Applications

---

- Calculators
- Electronic cash registers
- Point-of-sales equipment
- Audio-visual equipment
- Electrical home appliances
- Clocks
- Electrical automotive devices
- Office automation equipment
- Instrument panels

No matter how advanced the equipment, optimal performance cannot be obtained unless information can be read reliably and easily. NEC's fluorescent indicator panels, otherwise known as FIP® panels, are the ideal interface between man and machine. These blue-green, light-emitting displays are used in applications ranging from video decks and microwave ovens to automotive instrument panels and office automation equipment. Their exceptional quality, long life, and high reliability make NEC FIPs the perfect interface media.

NEC insists on implementing strict quality control measures at every stage of the manufacturing process, from design to shipment, to ensure the superior performance and long life of each and every product. In our FIP product line, this commitment to quality has resulted in a 10 ppm defect rate and made NEC's FIP panels a dependable, cost-effective choice for consumer and industrial applications alike.

## A Variety of Options for Every Type of Application

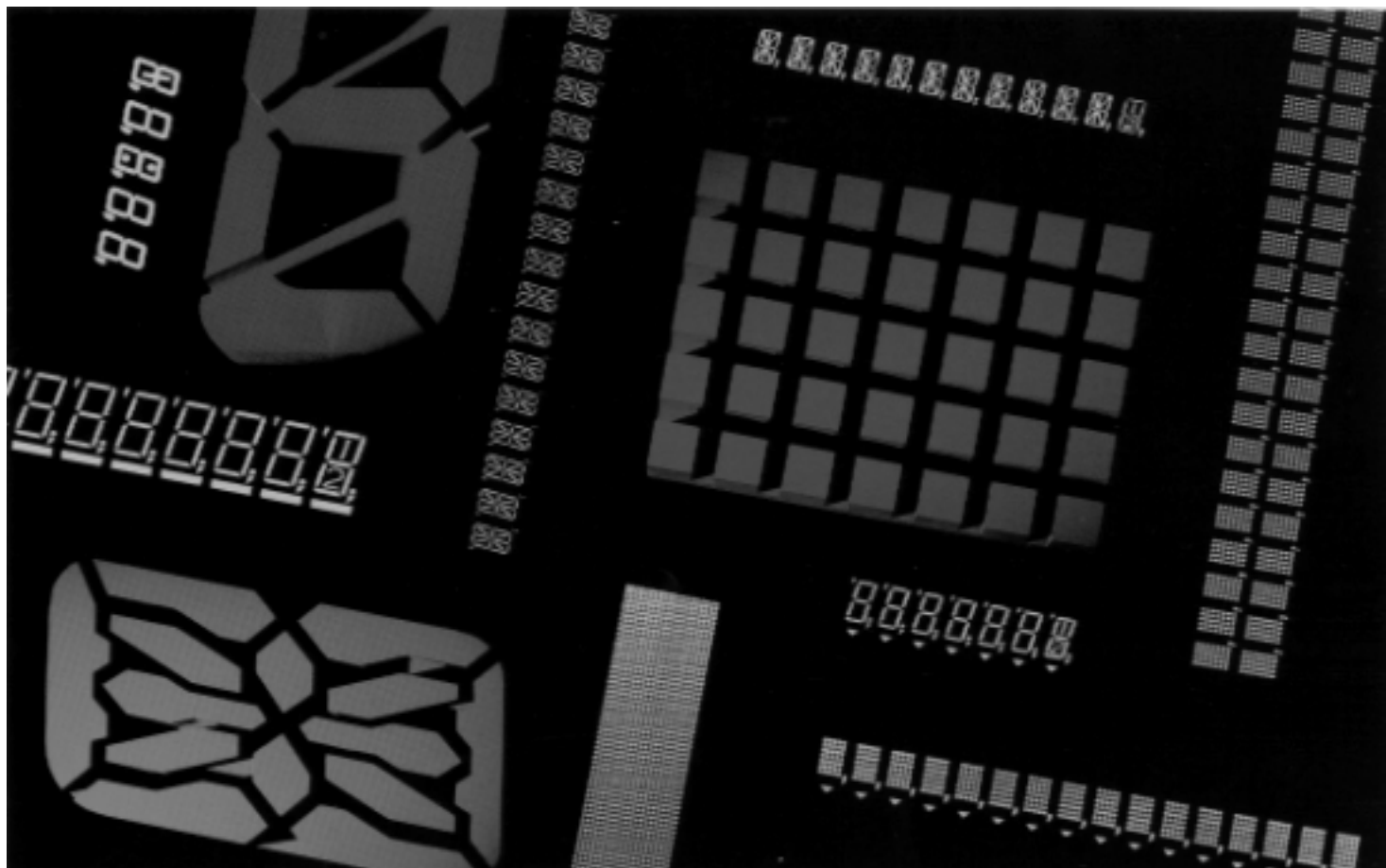

NEC offers an extensive variety of standard FIP panels. In addition, custom FIPs can also be designed to report information unique to a particular application. Whether standard or custom-designed, NEC's FIPs faithfully reproduce letters, numbers, and symbols in one of three formats: seven-segment, alphanumeric, or dot matrix.

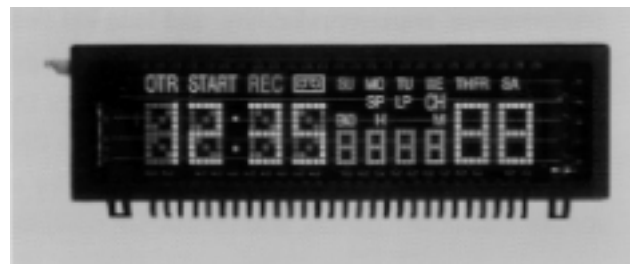



## Seven-Segment Display

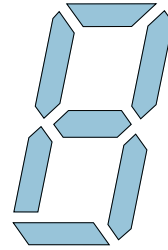

This display reproduces specific patterns such as numbers, simple letters, and elementary symbols.

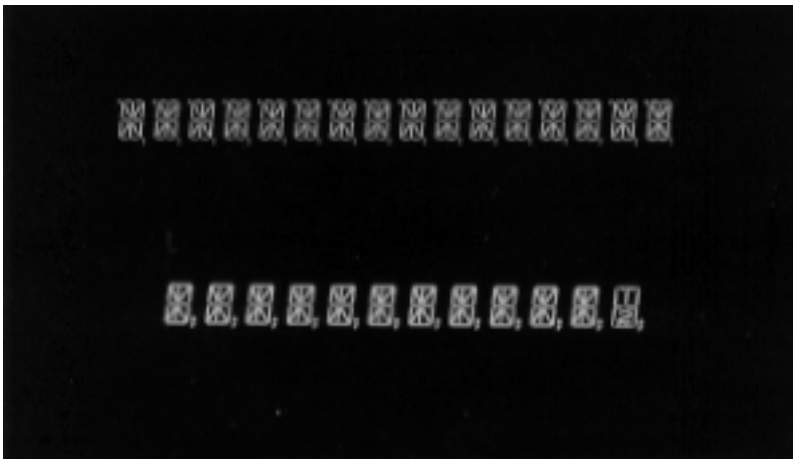

## Alphanumeric Display

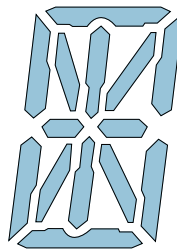

This display reproduces patterns composed of 14 segments to create more complicated alphanumeric characters than a seven-segment display.

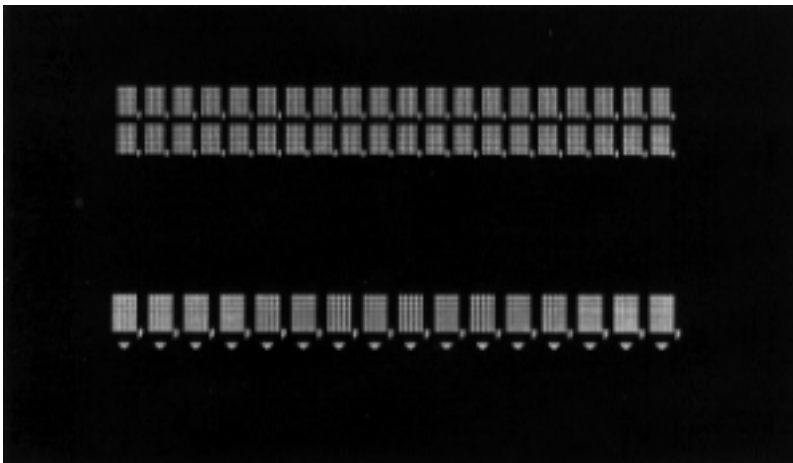



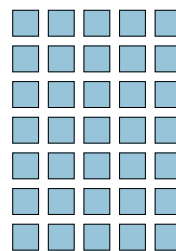













## Dot-Matrix Display



This display reproduces a very diverse selection of characters, numbers, and symbols using a high-definition  $5 \times 7$  or  $5 \times 12$  dot matrix.

# Selection Guide

## Dot and Graphic Type for Data Terminals

Type No.	No. of Digits (Digits × Lines)	Character Format, Symbol	Character Dimensions		Outline Dimensions				
			C.H (mm)	C.W (mm)	P.H (mm)	P.L (mm)	P.T (mm)	L.P (mm)	L.L (mm)
FIP12XM2FA	12×2		11.3	7.25	63.0±1.0	164.0±1.0	12.3±0.7	2.54	8.0
FIP16X1KB	16×1		5.0	3.3	19.5±1.0	96.7±1.0	6.5±0.7	2.54	6.2
FIP16X1PA	16×1		5.0	3.3	20.0±1.0	98.0±1.0	6.5±0.7	1.5	5.0
FIP16XM1BB	16×1		11.3	7.25	35.0±1.0	208.0±1.0	8.0±0.7	2.54	14.0
FIP16XM1DB	16×1		11.25	7.2	36.0±1.0	202.5±1.0	9.0±0.7	2.54	14.0
FIP16XM2AB	16×2		11.3	7.25	51.0±1.0	208.0±1.0	10.3±0.7	2.54	14.0
FIP19X1AC	19×1		10.5	6.0	33.0±1.0	205.0±1.0	8.0±0.7	2.54	8.0
FIP20X1XA	20×1		5.0	3.5	28.0±1.0	138.0±0.7	8.0±0.7	2.54	14.0
FIP20X1DD	20×1		9.0	6.3	34.0±1.0	208.0±1.0	8.0±0.7	2.54	14.0
FIP20X1LD	20×1		5.05	3.3	20.5±1.0	115.7±1.0	6.5±0.7	2.54	6.2
FIP20X1TA	20×1		8.99	6.3	34.0±1.0	202.5±1.0	8.0±0.7	2.54	14.0
FIP20XM1BB	20×1		11.3	7.25	35.5±1.0	244.0±1.0	9.0±0.7	2.54	14.0
FIP20XM1CB	20×1		10.5	6.2	44.0±1.0	225.0±1.0	10.3±0.7	2.54	9.2
FIP20X2AC	20×2		5.05	3.55	35.0±1.0	125.0±1.0	7.8±0.7	2.54	14.0
FIP20X2EB	20×2		5.05	3.55	41.0±1.0	142.0±1.0	10.3±0.7	2.54	14.0
FIP20X2KB	20×2		9.5	6.2	40.0±1.0	185.0±1.0	10.2±0.7	2.0	4.7

Package No.	Recommended Electrical Ratings									L	
	Filament	Ef (V rms)	If (mA rms)	Operation	eb = ec (Vp-p) *Eb = Ec (Vdc)	Duty	Ek (Vdc)	ib/dig (mA)	ic/dig (mA)	(cd/m <sup>2</sup> )	(fL)
D-4	AC	6.2	260	dynamic	36.0	1/27	8.2	13.0	13.0	1000	(290)
B-3	AC	3.9	84	dynamic	25.0	1/20	5.0	2.5	2.5	690	(200)
A-3	AC	4.0	84	dynamic	35.0	1/17	5.8	4.0	4.0	1000	(290)
C-4	AC	8.3	106	dynamic	35.0	1/20	7.0	20.0	20.0	1030	(300)
C-4	AC	8.3	133	dynamic	43.0	1/38	8.0	26.0	23.0	1700	(500)
D-4	AC	8.3	212	dynamic	35.0	1/20	10.0	30.0	25.0	1030	(300)
A-6	AC	7.7	159	dynamic	50.0	1/23	10.0	9.0	14.0	690	(200)
D-4	AC	5.5	84	dynamic	35.0	1/24	5.5	3.5	3.5	820	(240)
D-4	AC	6.4	120	dynamic	35.0	1/24	8.5	9.0	9.0	1000	(290)
B-5	AC	4.9	84	dynamic	27.0	1/25	6.0	2.7	2.9	680	(200)
C-4	AC	6.4	120	dynamic	45.0	1/76.8	10.0	21.0	15.0	860	(250)
D-4	AC	9.6	130	dynamic	45.0	1/25	10.0	20.0	25.0	1700	(500)
D-4	AC	8.8	186	dynamic	35.0	1/24	10.0	13.5	14.0	860	(250)
D-4	AC	6.0	125	dynamic	50.0	1/45	5.0	4.0	4.0	860	(250)
C-4	AC	6.0	168	dynamic	35.0	1/24	7.0	5.0	10.0	700	(200)
D-2	AC	6.6	200	dynamic	48.0	1/45	7.0	15.0	15.0	700	(200)







### Dot and Graphic Type for Data Terminals (cont'd)

Type No.	No. of Digits (Digits × Lines)	Character Format, Symbol	Character Dimensions		Outline Dimensions				
			C.H (mm)	C.W (mm)	P.H (mm)	P.L (mm)	P.T (mm)	L.P (mm)	L.L (mm)
FIP20X2LA	20 × 2		8.8	3.55	41.0±1.0	136.0±1.0	9.0±0.7	2.0	5.1
FIP20X2RA	20 × 2		11.3	7.25	53.0±1.0	250.0±1.0	10.3±0.7	2.54	16.5
FIP20XM2AB	20 × 2		10.5	6.2	68.0±1.0	225.0±1.0	12.5±0.7	2.54	6.8
FIP20XM2GA	20 × 2		11.3	7.25	58.0±1.0	246.0±1.0	12.0±0.7	2.54	14.0
FIP20XM2FA	20 × 2		8.1	5.35	54.0±1.0	175.0±1.0	10.6±0.7	2.54	4.5
FIP20X4AB	20 × 4		11.3	7.25	77.0±1.0	240.0±1.0	13.7±0.7	2.0	6.4
FIP20X4CB	20 × 4		5.0	3.3	53.5±1.0	125.0±1.0	10.5±0.7	1.6	6.0
FIP40X1HC	40 × 1		5.05	3.55	28.0±1.0	220.0±1.0	8.0±0.7	2.54	14.0
FIP40X2BC	40 × 2		9.35	3.55	50.0±1.0	238.0±1.0	11.5±0.7	2.54	5.5
FIP40X2CD	40 × 2		5.05	3.55	41.0±1.0	220.0±1.0	10.3±0.7	2.54	14.0
FIP48GX7CA	—		7.9	57.1	28.0±1.0	93.0±1.0	8.0±0.7	2.54	7.4
FIP64GX32AA	—		35.52	80.96	58.0±1.0	120.0±1.0	10.3±0.7	1.5	5.0
FIP72GX7CA	—		7.9	85.9	27.0±1.0	122.5±1.0	8.0±0.7	2.54	14.0
FIP192GX16AA	—		30.1	264.66	55.0±1.0	300.0±1.0	11.5±0.7	2.54	5.6









Package No.	Recommended Electrical Ratings									L	
	Filament	Ef (V rms)	If (mA rms)	Operation	eb = ec (Vp-p) *Eb = Ec (Vdc)	Duty	Ek (Vdc)	ib/dig (mA)	ic/dig (mA)	(cd/m <sup>2</sup> )	(fL)
B-2	AC	6.1	159	dynamic	45.0	1/45	8.2	8.5	15.0	700	(200)
C-4	AC	9.5	212	dynamic	35.0	1/24	10.0	30.0	25.0	860	(250)
D-4	AC	8.8	265	dynamic	45.0	1/44	10.0	28.0	25.0	860	(250)
D-4	AC	10.0	243	dynamic	50.0	1/45	15.0	22.0	15.0	860	(250)
C-4	AC	7.2	335	dynamic	45.0	1/44	10.0	20.0	20.0	860	(250)
D-4	AC	9.2	428	dynamic	35.0	1/24	10.0	14.0	60.0	600	(180)
C-4	AC	5.1	392	dynamic	52.0	1/50	6.8	6.0	7.0	700	(200)
D-4	AC	9.0	78	dynamic	45.0	1/50	7.0	7.5	7.0	690	(200)
C-4	AC	10.2	223	dynamic	45.0	1/50	10.0	15.0	15.0	700	(200)
D-4	AC	9.6	168	dynamic	45.0	1/50	9.0	8.0	15.0	690	(200)
B-5	AC	3.0	76	dynamic	35.0	1/18	5.0	30.0/1GRID	25.0/1GRID	1030	(300)
B-2	AC	4.4	344	dynamic	60.0	1/100	7.0	20.0/32DOT	8.0/1GRID	860	(250)
B-5	AC	4.2	76	dynamic	36.2	1/24	6.0	4.8/21DOT	6.0/1GRID	820	(240)
B-6	AC	10.0	456	dynamic	100/55	1/111	15.0	26.0/32DOT	17.0/2GRID	820	(240)

### Alphanumeric Type for Data Terminals

Type No.	No. of Digits	Character Format, Symbol	Character Dimensions		Outline Dimensions				
			C.H (mm)	C.W (mm)	P.H (mm)	P.L (mm)	P.T (mm)	L.P (mm)	L.L (mm)
FIP6A8BR	6		8.15	4.4	28.0±1.0	78.0±1.0	8.0±0.7	2.54	20.0
FIP10A6CR	10		6.0	3.0	20.0±1.0	86.0±1.0	6.5±0.7	2.54	26.8
FIP16J5R	16		5.0	3.0	20.0±1.0	110.0±1.0	6.5±0.7	2.54	10.0
FIP16J5AR	16		5.0	3.0	20.0±1.0	110.0±1.0	6.5±0.7	2.54	6.2
FIP16B13AR	16		12.5	7.0	33.0±1.0	205.0±1.0	8.0±0.7	5.08	10.0
FIP16D9R	16		9.35	4.8	35.0±1.0	170.0±1.0	8.0±0.7	2.54	14.0
FIP20D6R	20		6.0	3.0	20.0±1.0	134.0±1.0	6.5±0.7	2.54	14.0

### Alphanumeric Type for Automotive and Others

FIP4B6CS	4		6.0	3.0	18.5±1.0	44.0±1.0	6.5±0.7	2.0	8.7
FIP4A8FS	4		7.6	4.0	24.5±1.0	55.4±1.0	6.5±0.7	2.54	8.7
FIP4E8BS	4		7.6	4.0	20.0±1.0	48.0±1.0	6.1±0.5	2.54	8.2
FIP4Y8S	4		7.6	4.0	20.0±1.0	48.0±1.0	6.5±0.7	2.54	8.7
FIP4Q8S	4		8.0	4.4	20.0±1.0	48.0±1.0	6.5±0.7	2.54	8.2
FIP4Q8AS	4		8.0	4.4	20.0±1.0	48.0±1.0	6.5±0.7	2.54	5.0
FIP4BF8S	4		7.6	4.0	20.0±1.0	48.0±1.0	6.1±0.5	2.54	5.0







Package No.	Recommended Electrical Ratings									L	
	Filament	Ef (V rms)	If (mA rms)	Operation	eb = ec (Vp-p) *Eb = Ec (Vdc)	Duty	Ek (Vdc)	ib/dig (mA)	ic/dig (mA)	(cd/m <sup>2</sup> )	(fL)
A-2	AC	2.8	134	dynamic	26	1/20	5	4.5	9.8	620	(180)
C-1	AC	3.2	57	dynamic	26	1/11	5	2.5	2.5	850	(250)
A-1	AC	4.3	80	dynamic	24	1/20	6	2.5	3.0	690	(200)
A-3	AC	4.3	80	dynamic	24	1/20	6	2.5	3.0	690	(200)
A-2	AC	8.2	133	dynamic	47	1/20	10	13.0	12.0	1030	(300)
C-4	AC	5.4	120	dynamic	40	1/20	5.5	9.0	9.0	1030	(300)
D-3	AC	5.8	57	dynamic	32	1/24	7	3.5	3.5	1030	(300)
B-5	DC	1.6	57	static	*12	—	0	0.7	4.0	2060	(600)
B-5	DC	2.0	83	static	*12	—	0	1.5	8.4	2060	(600)
B-5	DC	1.4	78	static	*12	—	0	0.8	5.0	2060	(600)
B-5	DC	1.5	110	static	*12	—	0	1.4	8.0	2740	(800)
B-5	DC	1.5	110	static	*12	—	0	1.9	8.0	2740	(800)
B-5	DC	1.5	110	static	*12	—	0	1.9	8.0	2740	(800)
B-5	DC	1.4	102	static	*12	—	0	1.9	8.0	2740	(800)

### Alphanumeric Type for Digital Clocks, Timers, and Measuring Meters

Type No.	No. of Digits	Character Format, Symbol	Character Dimensions		Outline Dimensions				
			C.H (mm)	C.W (mm)	P.H (mm)	P.L (mm)	P.T (mm)	L.P (mm)	L.L (mm)
FIP4D15	4		15.0	8.4	33.0±1.0	98.0±1.0	8.0±0.7	2.54	11.0
FIP4F8CS	4		7.6	3.6	24.5±1.0	55.4±1.0	6.5±0.7	2.54	8.7
FIP4H5	4		5.0	2.5	14.5±1.0	41.0±1.0	6.5±0.7	2.54	8.0
FIP4Q8A	4		8.0	5.0	24.5±1.0	59.0±1.0	6.5±0.7	2.54	11.0
FIP5B15B	5		15.0	8.0	33.0±1.0	98.0±1.0	8.0±0.7	2.54	6.2
FIP5D8BS	5		7.6	3.6	24.5±1.0	55.4±1.0	6.5±0.7	2.54	8.7
FIP6C13E	6		12.5	6.8	33.0±1.0	98.0±1.0	8.0±0.7	4.0	10.5
FIP6C15E	6		15.0	8.0	33.0±1.0	110.0±1.0	8.0±0.7	4.0	10.5
FIP6D15C	6		15.0	7.5	33.0±1.0	98.0±1.0	8.0±0.7	2.54	15.0
FIP6D15D	6		15.0	7.5	33.0±1.0	98.0±1.0	8.0±0.7	2.54	6.5
FIP6F13A	6		12.5	6.8	33.0±1.0	98.0±1.0	8.0±0.7	2.54	5.2
FIP7B13	7		13.0	6.0	33.0±1.0	98.0±1.0	8.0±0.7	2.54	7.4
FIP7B25A	7		25.4	12.0	48.0±1.0	164.0±1.0	10.5±0.7	4.0	10.5
FIP7P8C	7		8.0	4.6	24.5±1.0	76.0±1.0	6.1±0.7	2.54	7.5

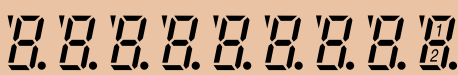
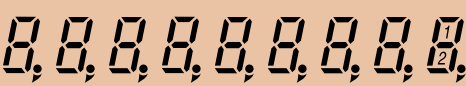
Package No.	Recommended Electrical Ratings									L	
	Filament	Ef (V rms)	If (mA rms)	Operation	eb = ec (Vp-p) *Eb = Ec (Vdc)	Duty	Ek (Vdc)	ib/dig (mA)	ic/dig (mA)	(cd/m <sup>2</sup> )	(fL)
A-6	AC	4.0	95	dynamic	22	1/5	5.5	9.0	10.0	1028	(300)
B-5	DC	1.9	81	static	*12	—	0	1.1	6.0	1370	(400)
A-4	DC	1.5	40	dynamic	22	1/4	2	0.5	1.0	1030	(300)
A-6	AC	2.4	81	dynamic	27	1/7	3.5	3.5	5.0	1030	(300)
C-2	AC	3.6	135	dynamic	43	1/28	5	12.0	15.0	620	(180)
B-5	DC	1.9	80	static	*12	—	0	0.8	6.0	1370	(400)
C-1	AC	3.8	113	dynamic	26	1/7	4	5.0	7.0	685	(200)
C-1	AC	4.1	161	dynamic	30 42	1/7.5	6	10.0 20.0	13.0 25.0	1370 3000	(400) (900)
A-3	AC	3.7	110	dynamic	35	1/16	5	13.0	20.0	1030	(300)
C-2	AC	3.7	110	dynamic	35	1/16	5	13.0	20.0	1030	(300)
C-2	AC	3.2	100	dynamic	42	1/21	4	9.5	11.0	1230	(360)
A-5	AC	3.3	104	dynamic	35	1/19	4	5.5	6.5	860	(250)
C-1	AC	5.5	175	dynamic	34.5	1/7.5	8	17.5	14.0	690	(200)
A-2	AC	2.3	106	dynamic	26	1/7	4	2.5	4.5	1370	(400)

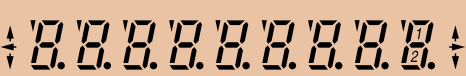
### Alphanumeric Type for Electronic Cash Registers and Others

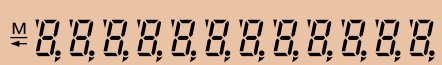
Type No.	No. of Digits	Character Format, Symbol	Character Dimensions		Outline Dimensions				
			C.H (mm)	C.W (mm)	P.H (mm)	P.L (mm)	P.T (mm)	L.P (mm)	L.L (mm)
FIP6A13C	6		13.0	6.5	39.0±1.0	108.0±1.0	8.0±0.7	2.54	10.0
FIP8B11C	8		10.5	5.0	33.0±1.0	98.0±1.0	8.0±0.7	2.54	5.2
FIP9H8	9		7.6	4.0	23.0±1.0	93.0±1.0	6.5±0.7	2.54	38.0
FIP9B10D	9		10.0	4.8	31.0±1.0	112.0±1.0	8.0±0.7	2.54	11.0
FIP9G13A	9		12.5	6.2	33.0±1.0	125.0±1.0	8.0±0.7	2.54	14.0
FIP11F10	11		9.6	4.2	24.5±1.0	113.0±1.0	7.5±0.7	2.54	16.0
FIP11B13B	11		18.0	6.0	33.0±1.0	147.0±1.0	8.0±0.7	2.54	7.4
FIP13Y8A	13		8.0	3.3	20.5±1.0	112.0±1.0	6.1±0.5	2.54	36.0

Package No.	Recommended Electrical Ratings									L	
	Filament	Ef (V rms)	If (mA rms)	Operation	eb = ec (Vp-p) *Eb = Ec (Vdc)	Duty	Ek (Vdc)	ib/dig (mA)	ic/dig (mA)	(cd/m <sup>2</sup> )	(fL)
A-2	AC	3.5	126	dynamic	35	1/16	7	5.0	8.0	690	(200)
C-2	AC	3.6	108	dynamic	47	1/32	6	6.0	8.0	620	(180)
C-1	AC	3.2	75	dynamic	25	1/14	5	6.0	7.0	1000	(292)
C-1	AC	3.5	75	dynamic	30	1/16	6	3.2	4.5	580	(170)
C-2	AC	3.9	140	dynamic	29	1/16	5	7.5	7.5	690	(200)
A-1	AC	4.8	78	dynamic	25	1/15	9.5	4.0	4.0	690	(200)
D-3	AC	5.5	78	dynamic	35	1/19	7	5.5	6.5	900	(263)
A-2	AC	4.2	55	dynamic	26	1/16	4	3.0	3.0	700	(200)

## Semicustom FIP Package

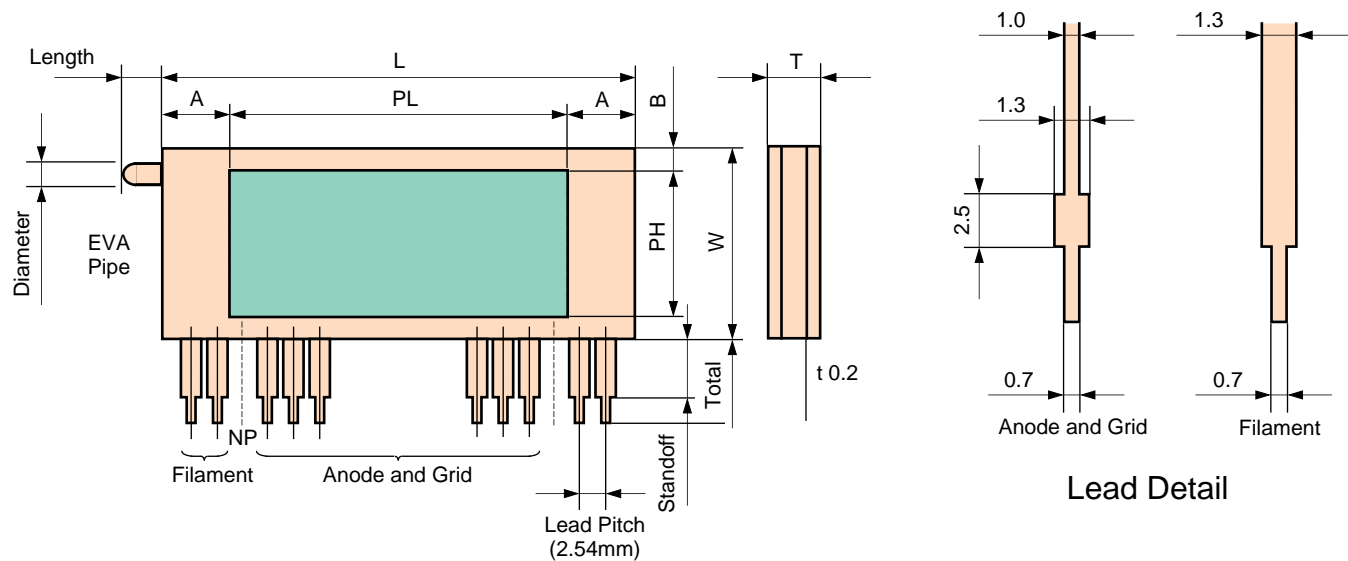

### Package List

No.	Package Size (mm)			Max. Graphic Area (mm)		Lead Terminal				EVA Pipe		Relative Position	
	W	L	T	PH	PL	Length (mm)		Number		Length (mm)	Diameter (mm)	A	B
						Total	Standoff	Filament	Anode and Grid				
1	25.0	67.2	6.1	13.5	41.2	15.0	9.5	4	16 max.	6 max.	ø 3 max.	13.0	5.5
2	25.0	98.0	6.1	13.5	72.0	15.0	9.5	4	29 max.	6 max.	ø 3 max.	13.0	5.5
3	25.0	129.0	6.1	13.5	103.0	15.0	9.5	4	41 max.	6 max.	ø 3 max.	13.0	5.5
4	29.0	78.4	7.5	17.0	52.4	15.0	9.5	4	21 max.	9 max.	ø 4 max.	13.0	5.5
5	29.0	98.0	7.5	17.0	72.0	15.0	9.5	4	29 max.	9 max.	ø 4 max.	13.0	5.5
6	29.0	110.2	8.0	17.0	84.2	15.0	9.5	4	33 max.	9 max.	ø 4 max.	13.5	5.5
7	29.0	125.0	8.0	17.0	99.0	15.0	9.5	4	39 max.	9 max.	ø 4 max.	13.5	5.5
8	29.0	135.2	8.0	17.0	109.2	15.0	9.5	4	43 max.	9 max.	ø 4 max.	13.5	5.5
9	33.5	98.0	8.0	21.5	71.0	15.0	9.5	4	29 max.	9 max.	ø 4 max.	13.5	5.5



### (1) General

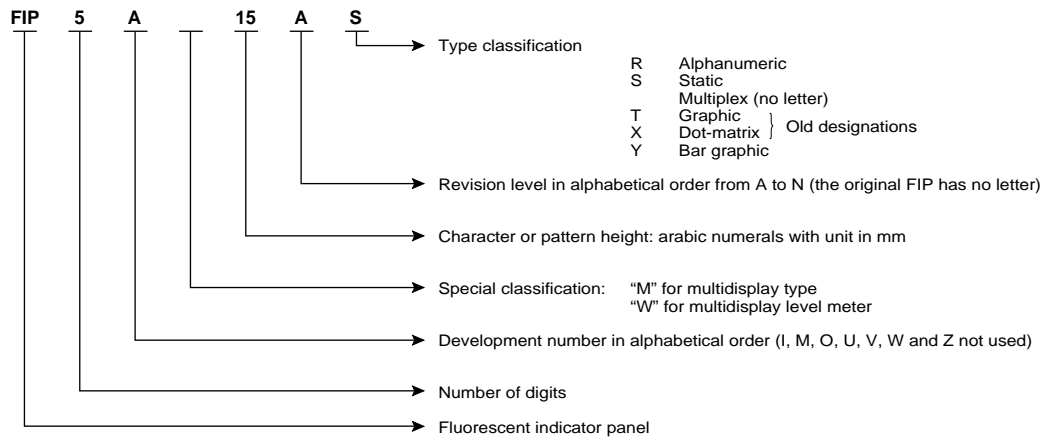

### (2) Dot-Matrix and Graphic Types

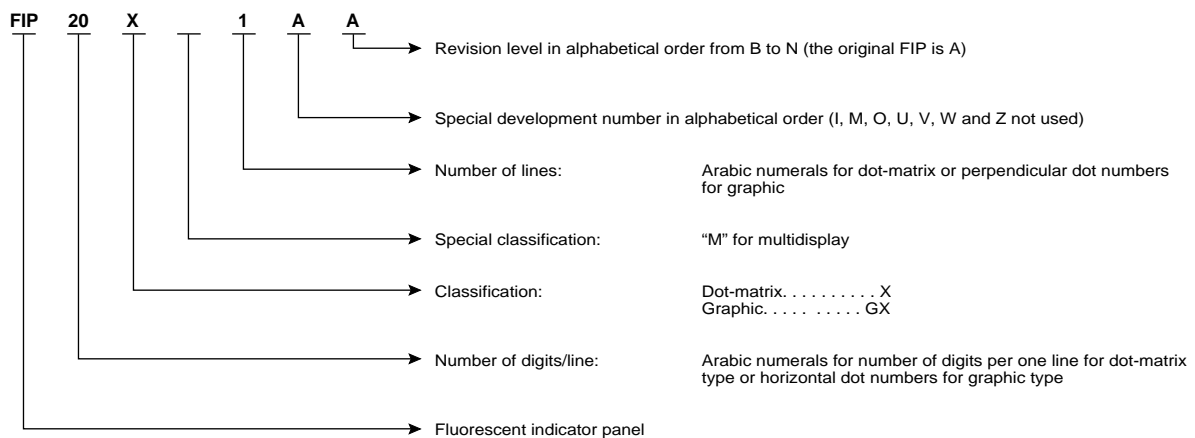

### Abbreviations

C.H.	Character height or pattern height	$E_b, E_c$	DC anode voltage and DC grid voltage
C.W.	Character width or pattern width	Duty	Duty cycle or duty factor
P.H.	Panel height	$E_k$	Cathode bias voltage or cutoff bias voltage
L.P.	Lead pitch	$i_b/\text{dig}$	Peak anode current per digit or per bar in multiplex operation; DC anode current per digit or per bar in static operation
L.L.	Lead length	$i_c/\text{dig}$	Peak grid current per digit in multiplex operation; DC grid current per panel in static operation
$E_f$	Filament voltage (AC = unit in V rms; DC = unit in $V_{dc}$ )	L	Brightness in $\text{cd/m}^2$ (SI unit) Bright value [ $\text{cd/m}^2$ ] shown in the table is the calculated value according to the equation. $1 [fL] = 3.43 [\text{cd/m}^2]$
$I_f$	Filament current (AC = unit in mA rms; DC = unit in $\text{mA}_{dc}$ )		
$e_b, e_c$	Peak anode voltage and peak grid voltage		

**A-1**

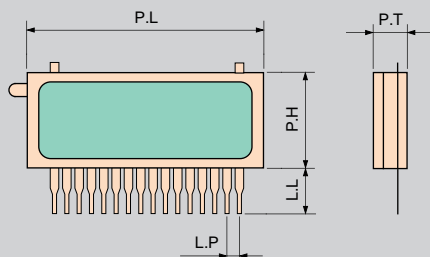

**A-2**

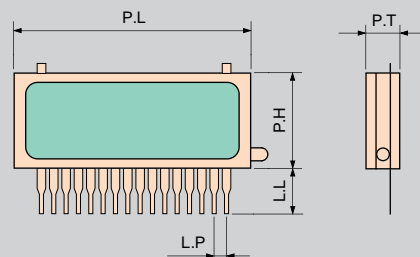

**A-3**

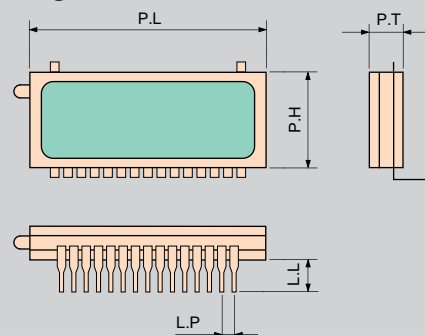

**A-4**

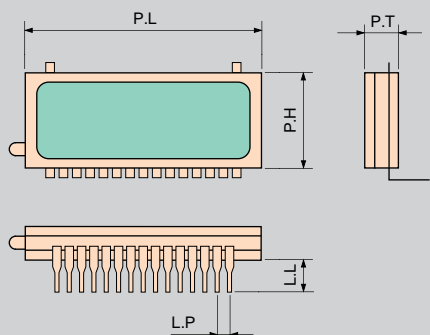

**A-5**

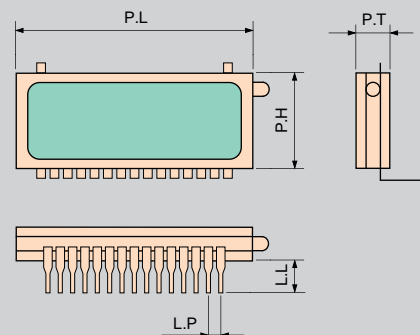

**A-6**

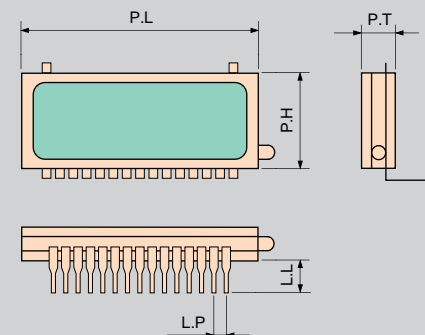

**B-1**

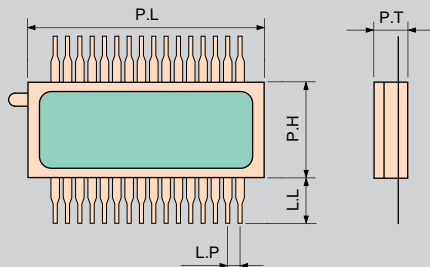

**B-2**

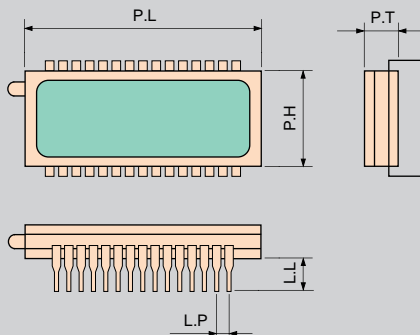

**B-3**

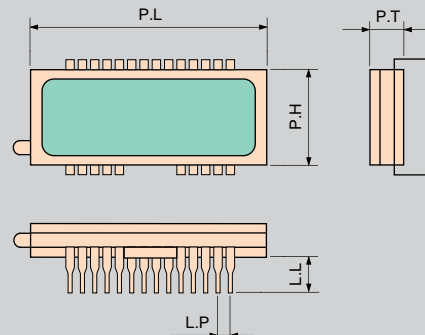

**B-4**

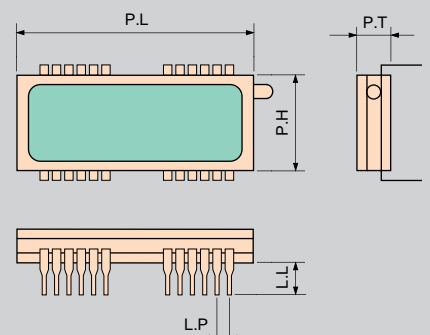

**B-5**

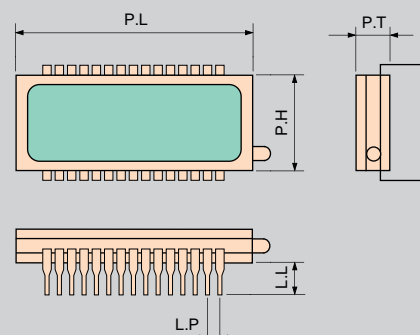

**B-6**

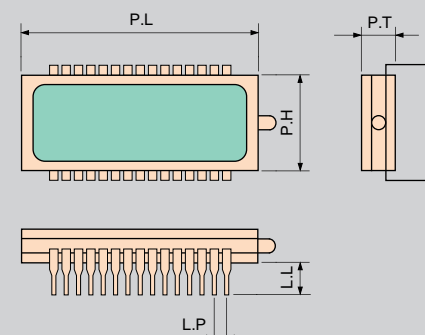

### C-1

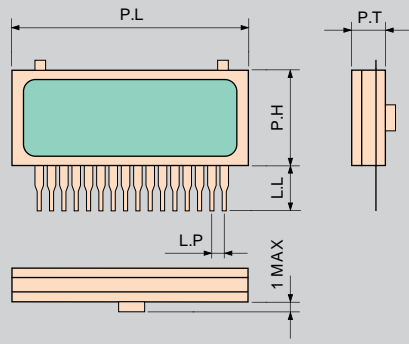

### C-2

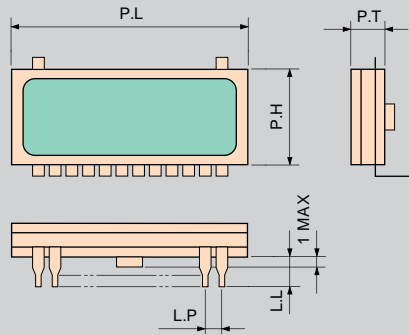

### C-3

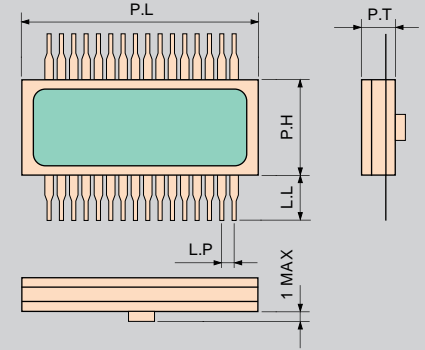

### C-4

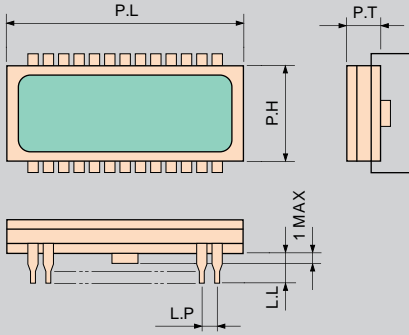

### D-1

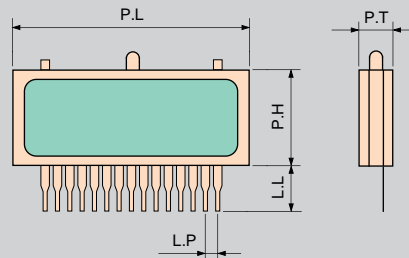

### D-2

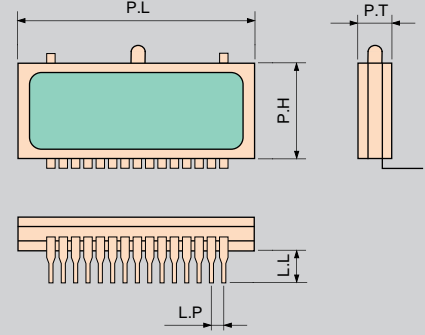

### D-3

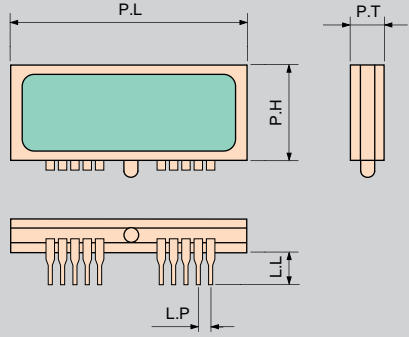

### D-4

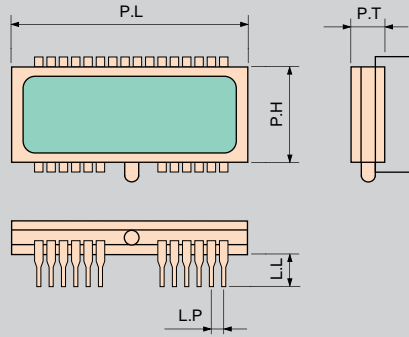

*A unique structure derived from NEC's advanced technology provides extraordinary quality and reliability.*

### Basic Structure

The basic structure of a FIP is equivalent to a directly heated triode vacuum tube. Anode segments with seven segments or any style of character configuration are applied with phosphor on the glass substrate, forming the vacuum vessel. Above them are control grids and filaments. After these electrodes are assembled, the inside is evacuated and the glass vessel is sealed using low-melting-point glass.

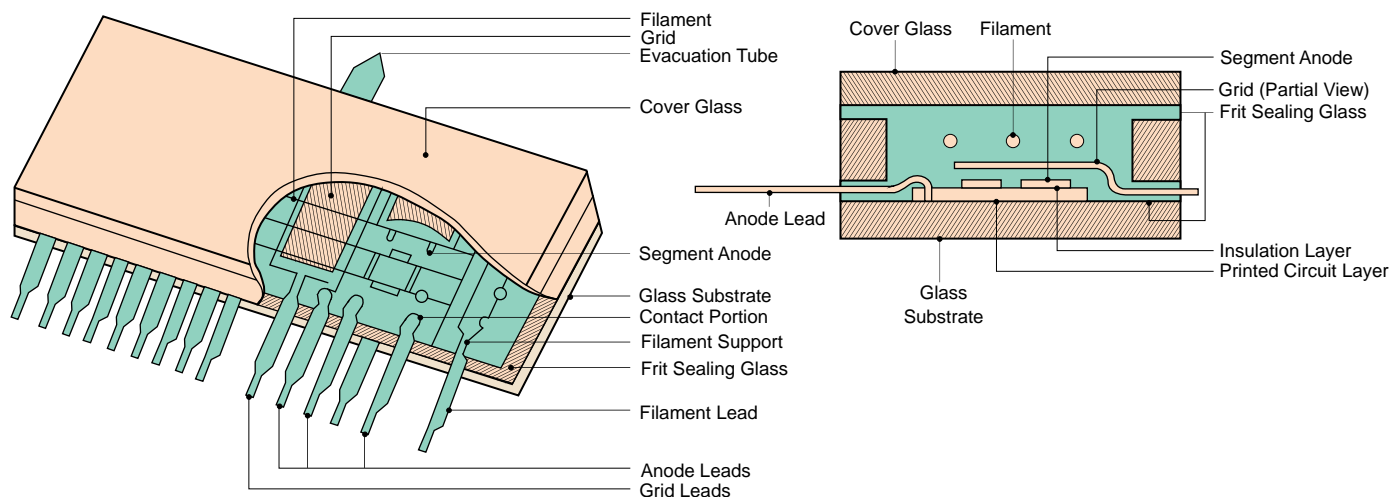

### Control and Operation

1. Normally ac voltage is applied to the filament and then heated to a high temperature. (In small-sized FIPs, heating with dc voltage is also possible.)
2. FIPs are driven by either static or dynamic (multiplex) charges. In static mode, only one grid controls all segments. In dynamic mode, multiple grids selected by time-sharing control the segments. Characters or symbols are displayed depending on the grid selected to apply a positive voltage to the filament.
3. Similarly, desirable anode segments are selected to apply the positive voltage.

The electrodes not selected receive a negative voltage. The state potential of the grid and the anode segment can be lowered to a minus level, in reference to the filament potential, using a simple power circuit employing a Zener diode.

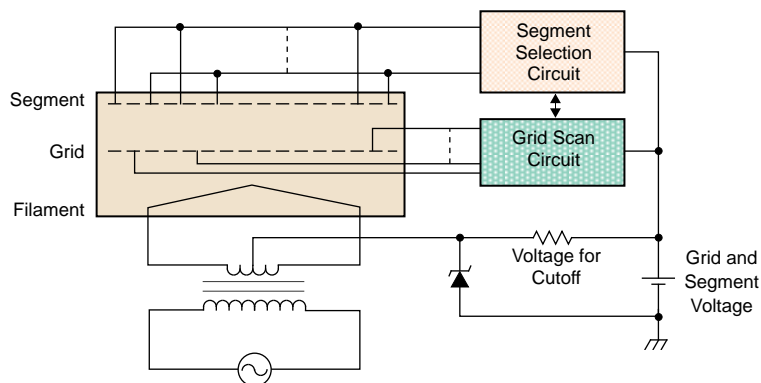

## Principle of Luminescence

1. Electrons are emitted by the heated filament.
2. The electrons are accelerated by the positive voltage of the selected control grid.
3. The electrons pass through the grid to the selected anode segment with a positive potential. The electrons then collide with the phosphor on the anode segment, causing light to be emitted.
4. A negative voltage is applied to the grids and anode segments that are not selected.

The green (standard) light is essentially compatible with the average human eye sensitivity curve, making the light easy to read.

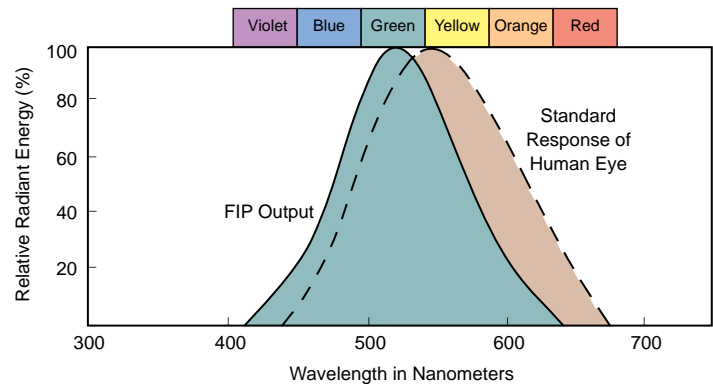

## Multicolor Display

The display color of FIPs can be altered in two ways.

1. Using a combination of different color phosphors, nine different colors are available. In a multicolor display, it is common to select the fluorescent material for standard green along with those for the other colors. Other colors selected are recommended for no more than ten percent of the entire display area.
2. Using filters, as illustrated below, the standard green phosphor  $\Delta$  contains all wavelengths in the visible light spectrum. Filters can be used to alter the color of the standard light as desired. Color options range from red to blue.

