

DISPLAY Elektronik GmbH

DATA SHEET

LCD MODULE

DEM 20486 SBH-PW-N

Product Specification

Version: 4

08.01.2018

GENERAL SPECIFICATION

MODULE NO. :

DEM 20486 SBH-PW-N

CUSTOMER P/N:

Version No.	Change Description	Date
0	Original Version	14.11.2007
1	Add Version	17.03.2009
2	Change LED Resistor	12.06.2009
3	Add LED Lifetime	06.12.2013
4	Change Maximum Parameter	08.01.2018

PREPARED BY: PS

DATE: 08.01.2018

APPROVED BY: MH

DATE: 08.01.2018

CONTENTS

1. FUNCTIONS & FEATURES2

2. MECHANICAL SPECIFICATIONS2

3. BLOCK DIAGRAM3

4. EXTERNAL DIMENSIONS3

5. PIN ASSIGNMENT4

6. PCB DRAWING AND DESCRIPTION5

7. BACKLIGHT & SWITCH.....6

8. DISPLAY DATA RAM (DDRAM)7

9. MAXIMUM ABSOLUTE LIMIT.....7

10. ELECTRICAL CHARACTERISTICS.....8

11. CONTROL AND DISPLAY COMMAND..... 10

12. STANDARD CHARACTER PATTERN (ST7066U-0A-B) 11

13. QUALITY DESCRIPTION 12

14. THE MODULE ACCEPTS QUALITY LEVEL (AQL)..... 13

15. RELIABILITY TEST 13

16. LCD MODULES HANDLING PRECAUTIONS 14

17. OTHERS..... 14

1. FUNCTIONS & FEATURES

MODULE NAME	LCD Type
DEM 20486 SBH-PW-N	STN-BLUE Transmissive Negative Mode

- Viewing Direction : 6 O'clock
- Driving Scheme : 1/16 Duty Cycle, 1/5 Bias
- Power Supply Voltage : 5.0 Volt (typ.)
- V_{LCD} ($V_{DD}-V_0$) : 4.5 Volt (typ.)
- Display Format : 20 x 4 Characters
- Internal Memory : CGROM (13,200 Bits)
: CGRAM (64 x 8 Bits)
: DDRAM (80 x 8 Bits for Digits)
- CGROM : CGROM of the ST7066U-0A-B
- Interface : Easy Interface with a 4-bit or 8-bit MPU

2. MECHANICAL SPECIFICATIONS

- Module Size : 98.00 x 60.00 x 14.50 mm
- Character Pitch : 4.10 x 7.00 mm
- Character Size : 3.45 x 6.35 mm
- Character Font : 5 x 8 Dots
- Dot Size : 0.65 x 0.75 mm
- Dot Pitch : 0.70 x 0.80 mm
- Dot Gap : 0.05 mm

3. BLOCK DIAGRAM

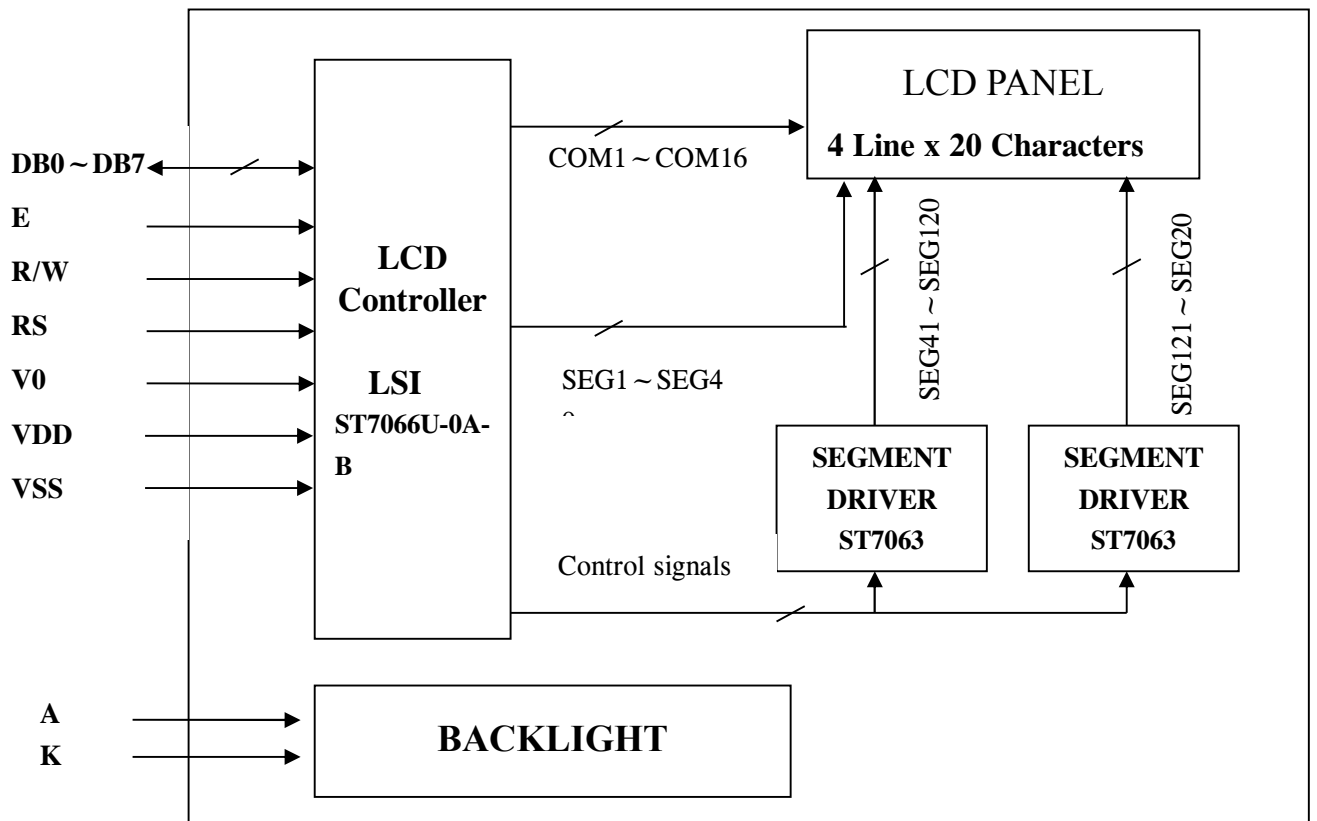

4. EXTERNAL DIMENSIONS

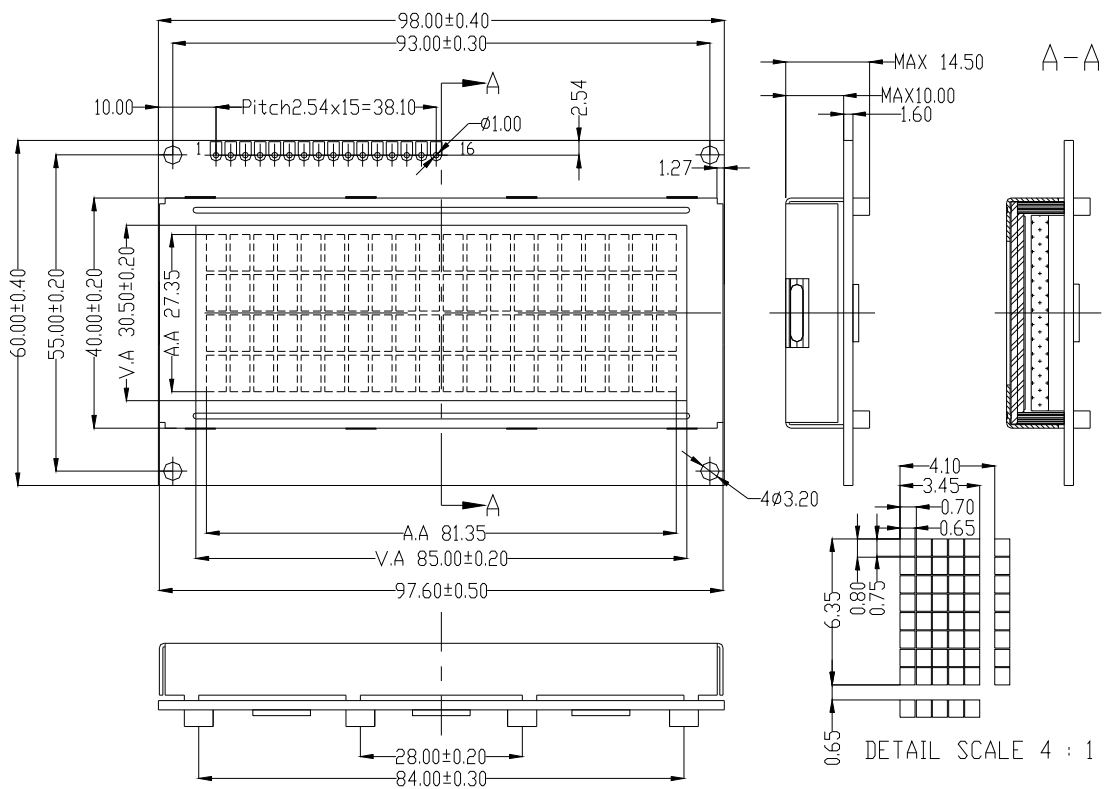

5. PIN ASSIGNMENT

Pin No.	Symbol	Function
1	VSS	Ground terminal of module
2	VDD	Power supply of module +5V
3	V0	Power Supply for LCD
4	RS	Register Select RS=0 (Instruction Register) RS=1 (Data Register)
5	R/W	Read or Write R/W=1 (Read) R/W=0 (Write)
6	E	Enable
7	DB0	Bi-directional Data Bus, Data Transfer is performed Once, thru DB0~DB7, in the case of interface data. Length is 8-bits; and twice, thru DB4~DB7 in the case of interface data length is 4-bits. Upper four bits first then lower four bits.
8	DB1	
9	DB2	
10	DB3	
11	DB4	
12	DB5	
13	DB6	
14	DB7	
15	LED-(K)	Place also refer to 6.1 PCB Drawing and description
16	LED-(A)	Place also refer to 6.1 PCB Drawing and description

6. PCB DRAWING AND DESCRIPTION

PCB Drawing

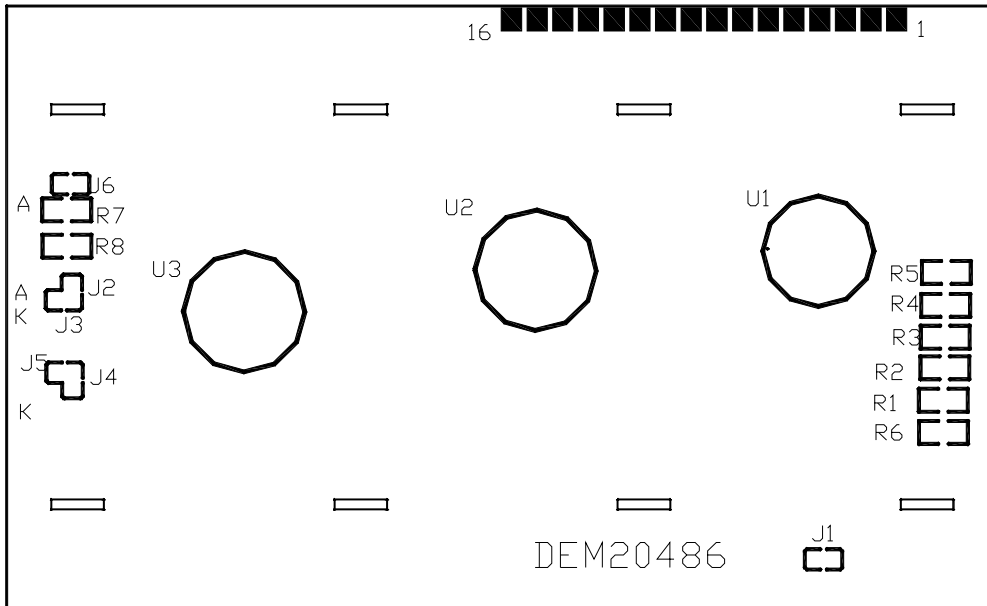

Note: The part no. DEM20486 is printed on the PCB.

DESCRIPTION:

6-1-1. The polarity of the pin 15 and the pin 16

LED Polarity	
15 Pin	16Pin
Anode	Cathode
J3=J5=open J2=J4=closed	

Note: In application module, J2=J4= open and J3=J5=closed

6-1-2. The metal-bezel is set be on ground when the J1 is closed.

Note: In application module, J1=closed

6-1-3. The LED resistor should can be bridged when the J6 is open.

Note: In application module, J6=open

6-1-4. The R7 and the R8 are the LED resistor.

Note: In application module, R7=33 Ohm, R8=47 Ohm

7. BACKLIGHT & SWITCH

Electronics/Optical Specifications:

	SYMBOL	MIN.	TYP.	MAX.	UNIT	CONDITIONS
Forward Voltage	V _f	3.7	4.0	4.2	V	I _f = 70 mA
Forward Current	I _f		70	85	mA	
Power Dissipation	P _d		0.28		W	I _f = 70 mA
Reverse Voltage	V _R		4.0		V	
Reverse Current	I _R		0.8		mA	
Luminous Intensity	I _v	350	450		cd/m	I _f = 70 mA
Luminous Uniformity		70			² %	I _f = 70 mA
Emission Wavelength	X	0.27		0.32	nm	I _f =20mA T _a =25°C Each chip
	Y	0.27		0.32		

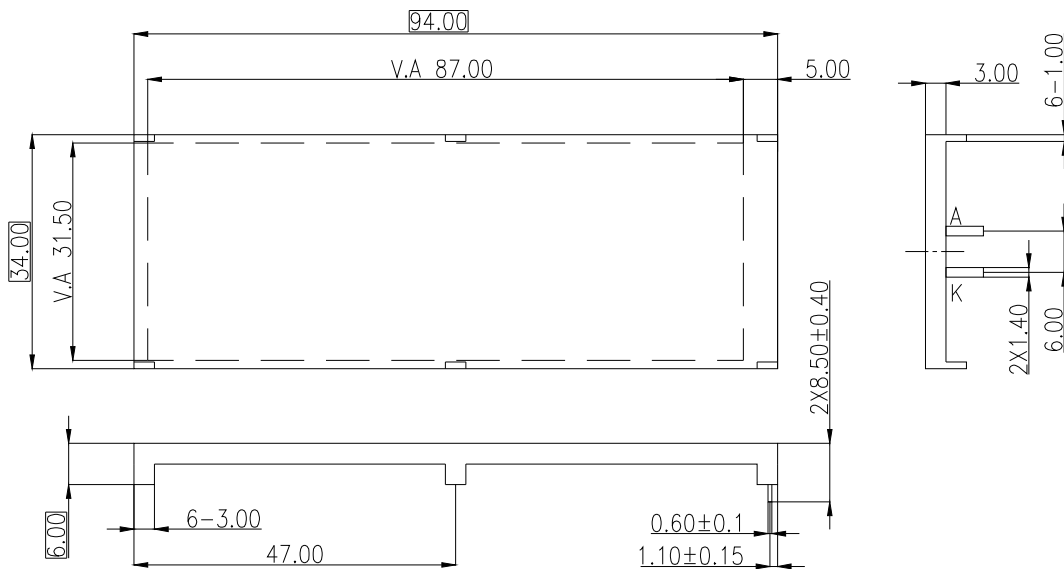

- Remarks:
1. Unmarked tolerance is ±0.3
 2. All materials comply with RoHs
 3. :critical dimension
 4. The LED lifetime 30000H.

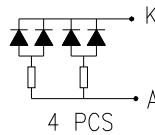

8. DISPLAY DATA RAM (DDRAM)

	1	2	3	4	5	6	7	8	9	10	11	12	13	14	15	16	17	18	19	20	← DISPLAY POSITION
FIRST LINE	00	01	02	03	04	05	06	07	08	09	0A	0B	0C	0D	0E	0F	10	11	12	13	← DDRAM ADDRESS
SECOND LINE	40	41	42	43	44	45	46	47	48	49	4A	4B	4C	4D	4E	4F	50	51	52	53	
THIRDD LINE	14	15	16	17	18	19	1A	1B	1C	1D	1E	1F	20	21	22	23	24	25	26	27	
FOURTH LINE	54	55	56	57	58	59	5A	5B	5C	5D	5E	5F	60	61	62	63	64	65	66	67	

9. MAXIMUM ABSOLUTE LIMIT

Item	Symbol	Standard value	Unit
Power Supply Voltage (1)	V _{DD}	-0.3~+6.0	V
Power Supply Voltage (2)	V ₀	V _{DD} -10.0~V _{DD} +0.3	V
Input Voltage	V _{IN}	-0.3~V _{DD} +0.3	V
Operating Temperature	Topr	-20~+70	°C
Storage Temperature	Tstg	-30~+80	°C

*Voltage greater than above may damage to the Circuit.

$$V_{DD} > V_1 > V_2 > V_3 > V_4 > V_5$$

10. ELECTRICAL CHARACTERISTICS

10-1 DC Characteristics

Item	Symbol	Standard Value			Test Condition	Unit
		MIN	TYP	MAX		
Operating Voltage	V_{DD}	4.5	5	5.5	-----	V
Supply Current	I_{DD}	----	1.72	2.58	$V_{DD}=5V, f_{osc}=270kHz$	mA
LCD Driving Voltage	V_{LCD}	4.2	4.5	4.5	$V_{DD}-V_5$ (1/5, 1/4 Bias)	V

10-2 AC Characteristics

10-2-1 Write Mode

Characteristic	Symbol	Min	Type	Max	Unit	Test PIN
E Cycle Time	t_c	1200	---	---	ns	E
E Rise Time	t_r	---	---	25	ns	E
E Fall Time	t_f	---	---	25	ns	E
E Pulse width	t_w	140	---	---	ns	E
Address Setup Time	t_{SU1}	0	---	---	ns	R/W, RS, E
Address Hold Time	t_{H1}	10	---	---	ns	R/W, RS, E
Data Set-up Time	t_{SU2}	40	---	---	ns	DB0~DB7
Data Hold Time	t_{H2}	10	---	---	ns	DB0~DB7

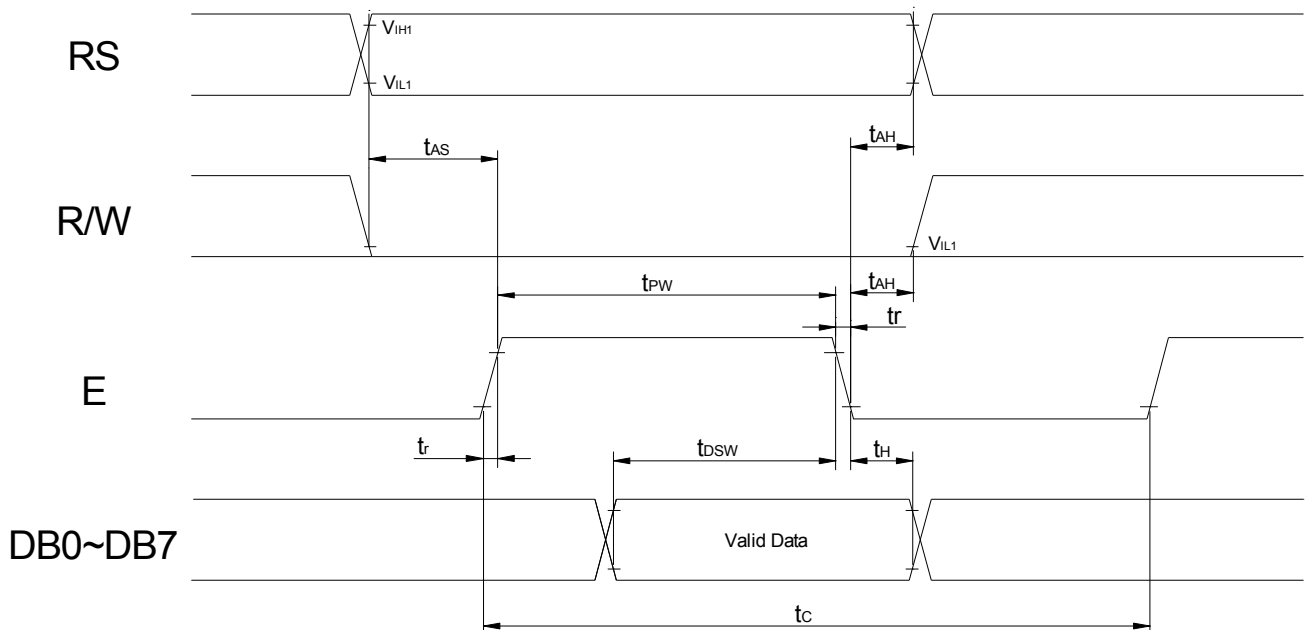

10-2-2 Read Mode

Characteristic	Symbol	Min	Type	Max	Unit	Test PIN
E Cycle Time	t_c	1200	---	---	ns	E
E Rise Time	t_R	---	---	25	ns	E
E Fall Time	t_F	---	---	25	ns	E
E Pulse width	t_{pw}	140	---	---	ns	E
Address Setup Time	t_{AS}	0	---	---	ns	R/W,RS,E
Address Hold Time	t_{AH}	10	---	---	ns	R/W,RS,E
Data Setup Time	t_{DDR}	---	---	100	ns	DB0~DB7
Data Hold Time	t_H	10	---	---	ns	DB0~DB7

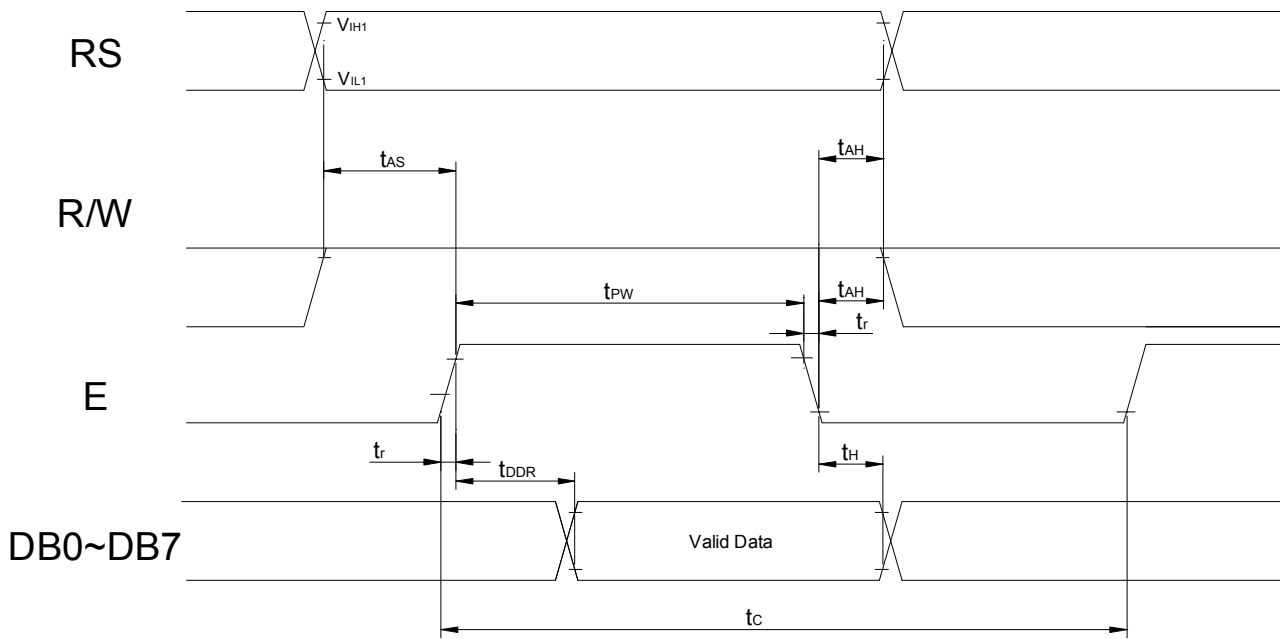

11. CONTROL AND DISPLAY COMMAND

Command	RS	R/W	DB7	DB6	DB5	DB4	DB3	DB2	DB1	DB0	Execution time (fosc=270KHz)	Remark
Clear Display	0	0	0	0	0	0	0	0	0	1	1.52ms	Write"20H" to DDRAM. And set DDRAM address to "00H" from AC
Return home	0	0	0	0	0	0	0	0	1	x	1.52ms	Set DDRAM address to "00H" from AC and return cursor to its original position if shifted. The contents of DDRAM are not changed.
Entry mode Set	0	0	0	0	0	0	0	1	I/D	S	37us	Sets cursor move direction and specifies display shift. These operations are performed during data write and read.
Display on/off control	0	0	0	0	0	0	1	D	C	B	37us	D=1: entire display on C=1: cursor on B=1: cursor position on
Cursor or Display Shift	0	0	0	0	0	1	S/C	R/L	x	x	37us	Set cursor moving and display shift control bit, and the direction, without changing DDRAM data.
function Set	0	0	0	0	1	DL	N	F	x	x	37us	DL: interface data is 8/4 bits N: number of line is 2/1 F: font size is 5x11/5x8
Set CGRAM address	0	0	0	1	AC5	AC4	AC3	AC2	AC1	AC0	37us	Set CGRAM address in address counter
Set DDRAM address	0	0	1	AC6	AC5	AC4	AC3	AC2	AC1	AC0	37us	Set DDRAM address in address counter
Read busy flag& address	0	1	BF	AC6	AC5	AC4	AC3	AC2	AC1	AC0	0us	Whether during internal operation or not can be known by reading BF. The contents of address counter can also be read.
Write data to RAM	1	0	D7	D6	D5	D4	D3	D2	D1	D0	37us	Write data into internal RAM (DDRAM/CGRAM)
Read data from RAM	1	1	D7	D6	D5	D4	D3	D2	D1	D0	37us	Read data from internal RAM (DDRAM / CGRAM)

Note:

Be sure the ST7066U is not in the busy state (BF=00 before sending an instruction from the MPU to the ST7066U. If an instruction is sent without checking the busy flag, the time between the first instruction and next instruction will take much longer than the instruction time itself. Refer to instruction table for the list of each instruction execution time.

12. STANDARD CHARACTER PATTERN (ST7066U-0A-B)

Upper(bits) / Lower(bits)		Upper(bits)															
		0000	0001	0010	0011	0100	0101	0110	0111	1000	1001	10010	1011	1100	1101	1110	1111
0000	CGRAM (1)																
0001	(2)																
0010	(3)																
0011	(4)																
0100	(5)																
0101	(6)																
0110	(7)																
0111	(8)																
1000	(1)																
1001	(2)																
1010	(3)																
1011	(4)																
1100	(5)																
1101	(6)																
1110	(7)																
1111	(8)																

13. QUALITY DESCRIPTION

DEFECT SPECIFICATION:

Specific type-related items are covered in this sheet.

- a: Table for Cosmetic defects
(Note: nc = not counted).
Sizes and number of defects
(Max. Qty)

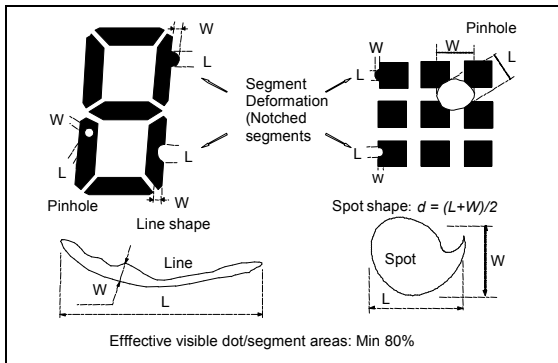

Examples/

Shapes

- b: Glass defects
- b1: Glass defects at contact ledge

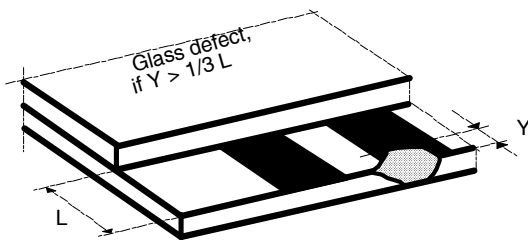

b2: Glass chipping in other areas shall not be in conflict with the product's function.

Defect Type	Max. defect size [μm] d or L W	Max. Quantity.
Black or White Spots	$d \leq 150$	nc
	$150 < d \leq 300$	3
Black or White Lines	-- $W \leq 10$	nc
	$L \leq 3000$ $W \leq 30$	2
Pinhole	$L \leq 2000$ $W \leq 50$	1
	$d \leq 100$ $100 < d \leq 200$	nc 1/segment
(Total defects)		(5)
Segment Deformation	$W \leq 100$	nc
Bubble (e.g. under pola)	$d \leq 150$	nc
	$300 < d \leq 600$	3

14. THE MODULE ACCEPTS QUALITY LEVEL (AQL)

- 14.1. AQL standard value: Critical defect =0.1, Major defect=0.65; Minor defect =2.5.
 14.2. Inspection Plan: MIL-STD-105E, Normal Inspection Level II, Single Sampling Plan.

15. RELIABILITY TEST

Operating life time: 50,000 hours (at room temperature without direct irradiation of sunlight)
 Reliability characteristics shall meet following requirements.

Test Item	Test Condition
High Temperature Storage	+80°C x 96 hrs
Low Temperature Storage	-30°C x 96 hrs
High Temperature Operation	+70°C x 96 hrs
Low Temperature Operation	-20°C x 96 hrs
High Temperature, High Humidity	+60°C x 90%RH x 96 hrs
Thermal Shock	-20°C x 30min → 25°C x 10s → +70°C x 30min x 5 Cycles
Vibration Test	Frequency x Swing x Time 40Hz x 4mm x 4 hrs
Drop Test	Height x No. of Drop 1.0m x 6 drops

16. LCD MODULES HANDLING PRECAUTIONS

- Please remove the protective foil of polarizer before using.
- The display panel is made of glass. Do not subject it to a mechanical shock by dropping it from a high place, etc.
- If the display panel is damaged and the liquid crystal substance inside it leaks out, do not get any in your mouth. If the substance come into contact with your skin or clothes promptly wash it off using soap and water.
- Do not apply excessive force to the display surface or the adjoining areas since this may cause the color tone to vary.
- The polarizer covering the display surface of the LCD module is soft and easily scratched. Handle this polarize carefully.
- To prevent destruction of the elements by static electricity, be careful to maintain an optimum work environment.
 - Be sure to ground the body when handling the LCD module.
 - Tools required for assembly, such as soldering irons, must be properly grounded.
 - To reduce the amount of static electricity generated, do not conduct assembly and other work under dry conditions.
 - The LCD module is coated with a film to protect the display surface. Exercise care when peeling off this protective film since static electricity may be generated.
- Storage precautions
When storing the LCD modules, avoid exposure to direct sunlight or to the light of fluorescent lamps. Keep the modules in bags designed to prevent static electricity charging under low temperature / normal humidity conditions (avoid high temperature / high humidity and low temperatures below 0°C). Whenever possible, the LCD modules should be stored in the same conditions in which they were shipped from our company.

17. OTHERS

- Liquid crystals solidify at low temperature (below the storage temperature range) leading to defective orientation of liquid crystal or the generation of air bubbles (black or white). Air bubbles may also be generated if the module is subjected to a strong shock at a low temperature.
- If the LCD modules have been operating for a long time showing the same display patterns may remain on the screen as ghost images and a slight contrast irregularity may also appear. Abnormal operating status can be resumed to be normal condition by suspending use for some time. It should be noted that this phenomena does not adversely affect performance reliability.
- To minimize the performance degradation of the LCD modules resulting from caused by static electricity, etc. exercise care to avoid holding the following sections when handling the modules:
 - Exposed area of the printed circuit board
 - Terminal electrode sections