

AC Axial Fans

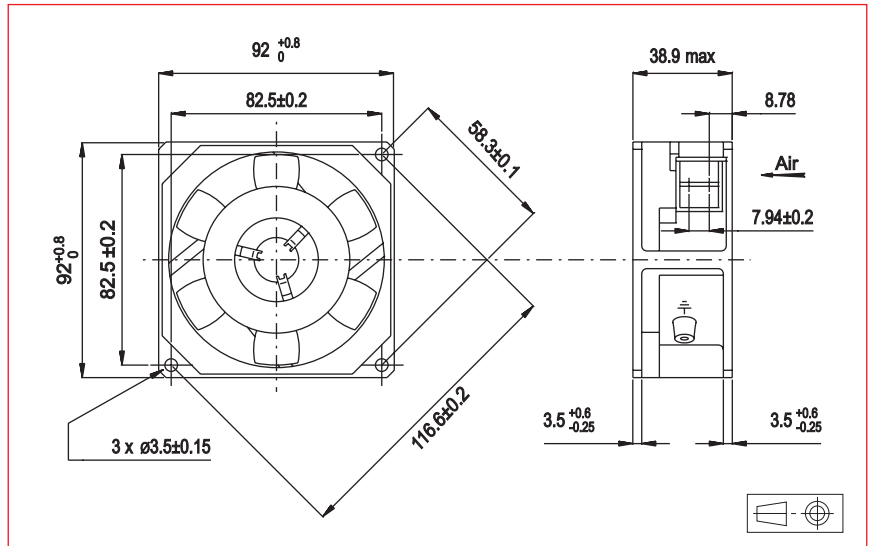

Approvals



Life expectancy

L-10 LIFE AT 40°C:
80 000 hours

AC Motor

Electrical protection: impedance protected
Housing material: zamak
Impeller material: plastic UL 94 V0
Maximum weight: 615 g
Bearing system: ball bearings
Connection: terminals

Single phase
IP 20

Available with:

- Flying leads
- IP 54

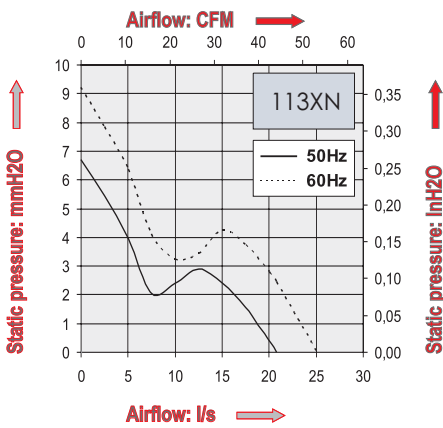

Part Number	Nominal voltage	Airflow	Noise level	Nominal speed	Frequency	Input Power	Nominal current	Starting current	Operating temperature	
	V								l/s	dB(A)
113XN0182001	115	21	36	2850	50	10	140	270	-10	70
		25	41	3300	60	9	115	220	-10	70
113XN0181001	208-240	21	36	2850	50	12	85	160	-10	70
		25	41	3300	60	11	75	140	-10	70

Additional versions:
Shock and vibration protected - salt spray protected - marine specifications - wide temperature range

